

Napoleon by Neal Elias Illustrated by Dave Venables

I strongly recommend practising exercises
11 & 12 - Construction of Nose and Chin
for Busts

Rectangle 12cm. x 48cm.
Model 11 cm. high

Begin with a 4 x 1 rectangle

Pre-crease a grid 8 x 32
then make pleats as shown

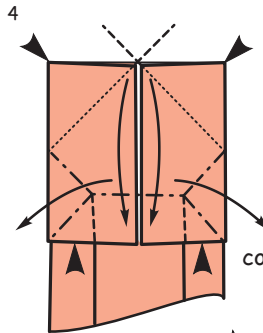
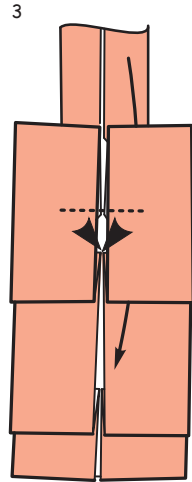
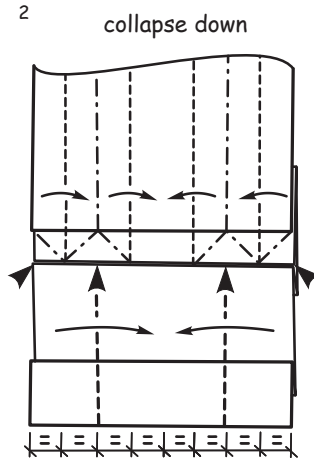
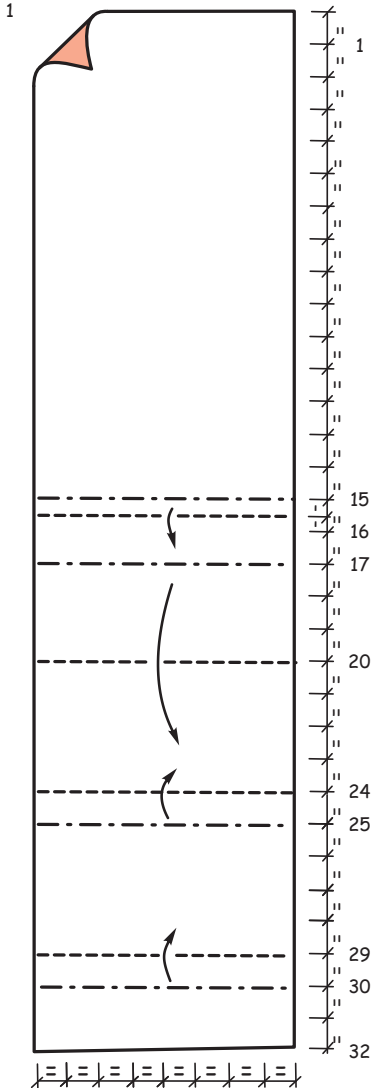

reverse
inside corners
then fold down
the long pleated
section

complex swivel folds

5
same move
showing cut away
view

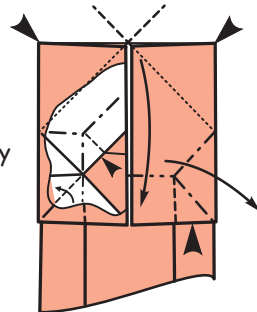

6

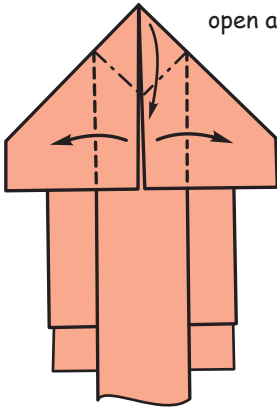

open and squash

7

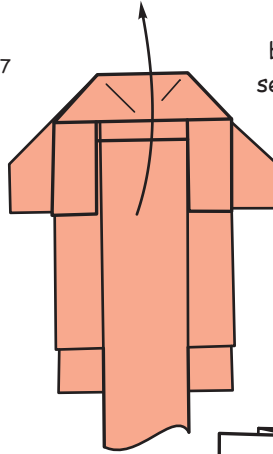

bring pleated section back up

8

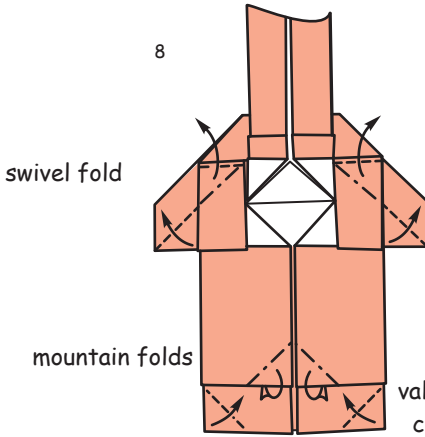

swivel fold

mountain folds

valley fold corners

10

9

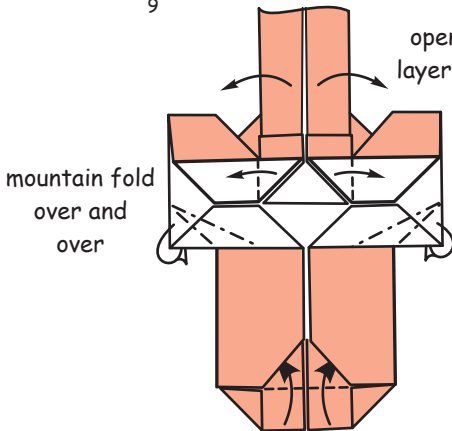

open out one layer each side

mountain fold over and over

fold top layer only

tuck into pockets

11

form a box section
point 'b' is
concave

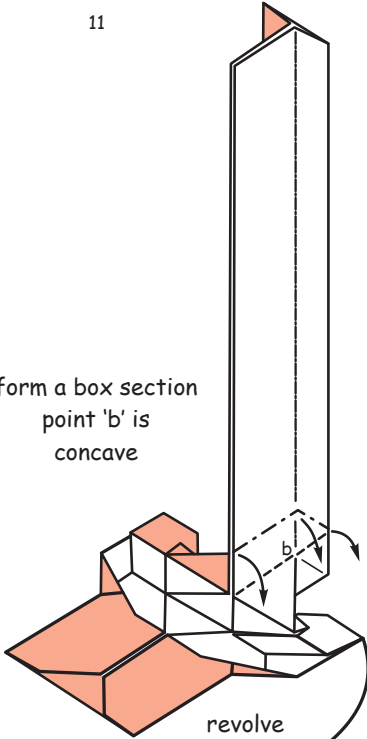

12

flatten
down

- revolve again

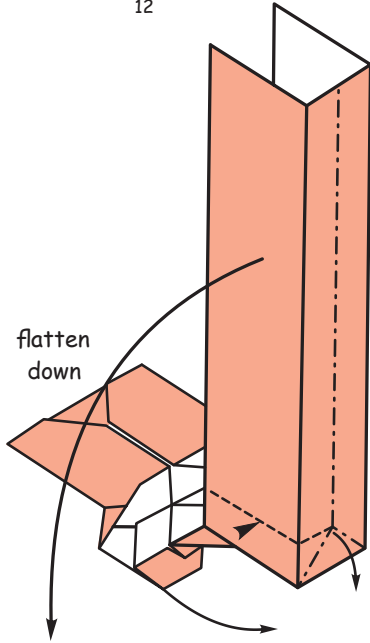

13

double sided
pleats and
squash

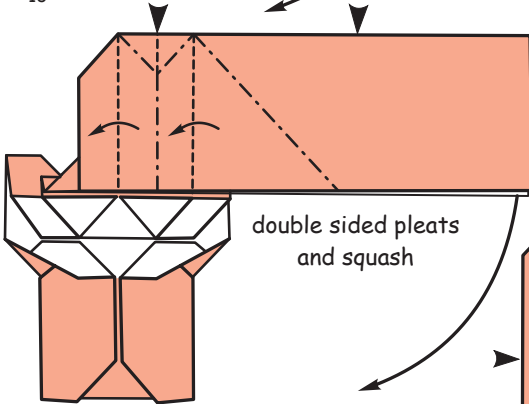

petal fold

14

turn over

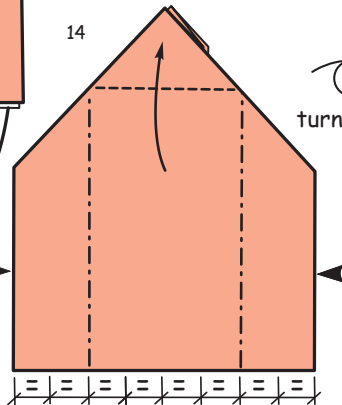

15

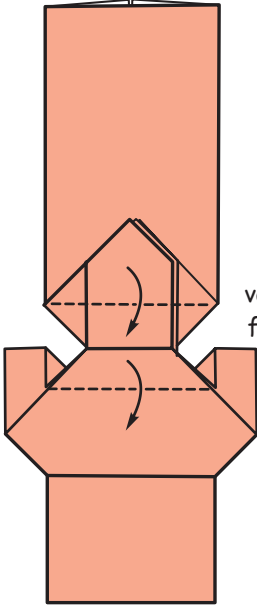

16

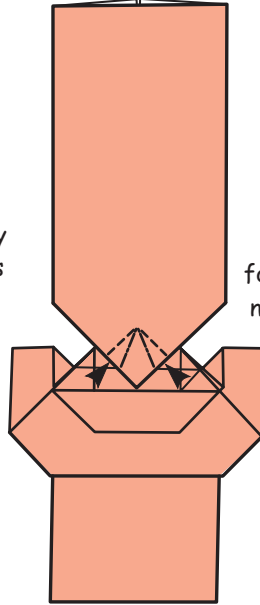

valley folds

see exercise 11 & 12
Construction of Nose and Chin
for Busts

form nose

17

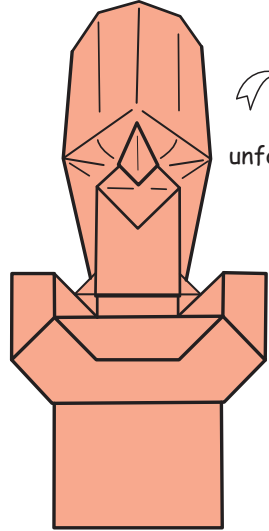

unfold

18

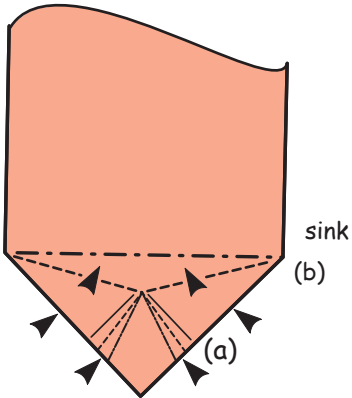

(a) form nose again
using new creases
then (b) sink

19

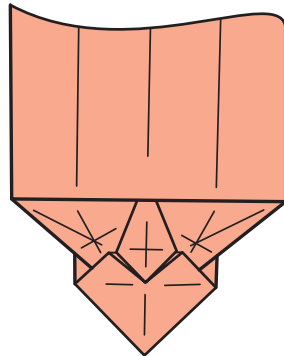

- nose completed

20

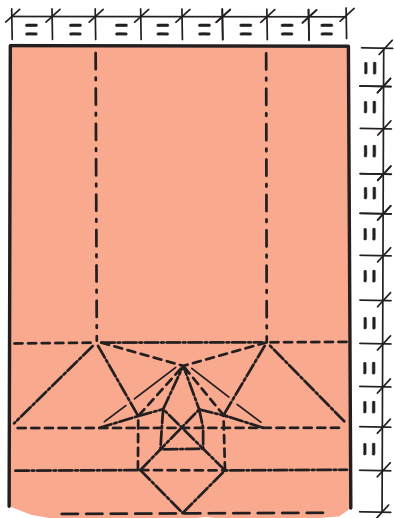

crease pattern for head at this stage

2

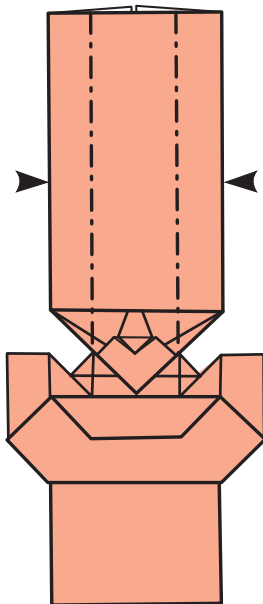

22

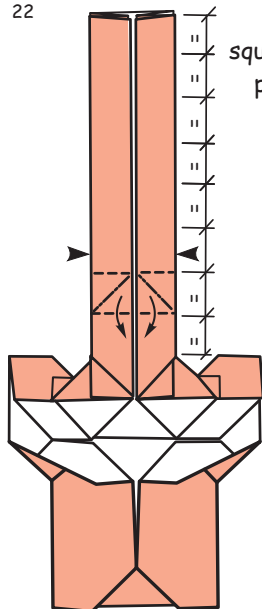

squash top and pleat each side

23

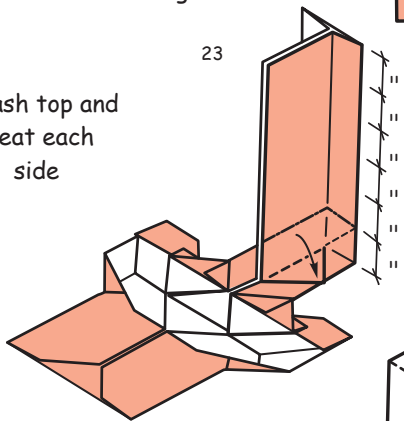

open up into a box section

carefully collapse down

24

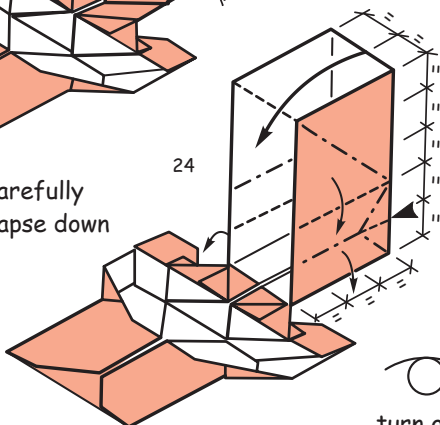

turn over



turn over

25

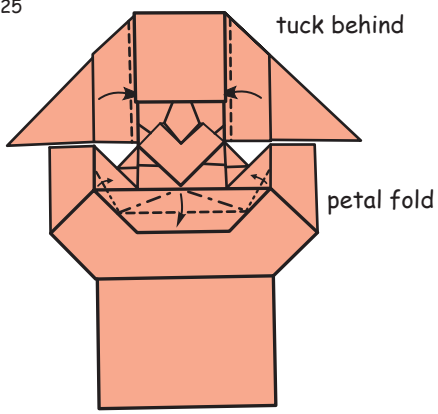

26

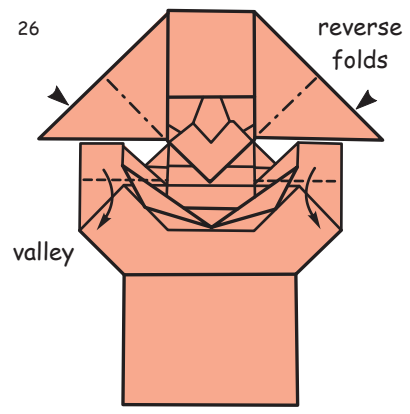

27

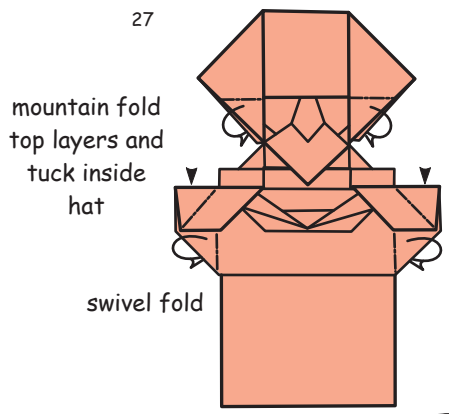

28

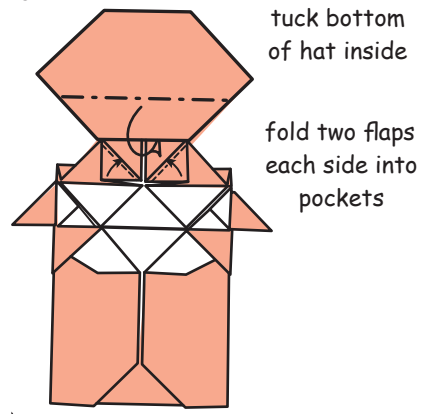

29

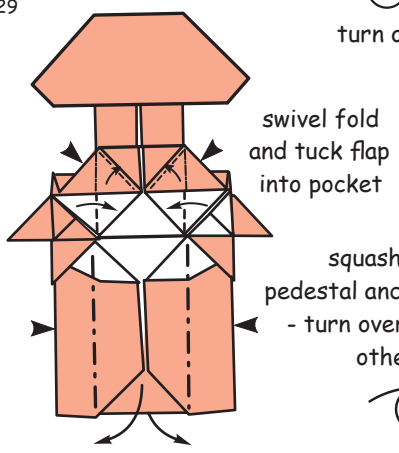

30

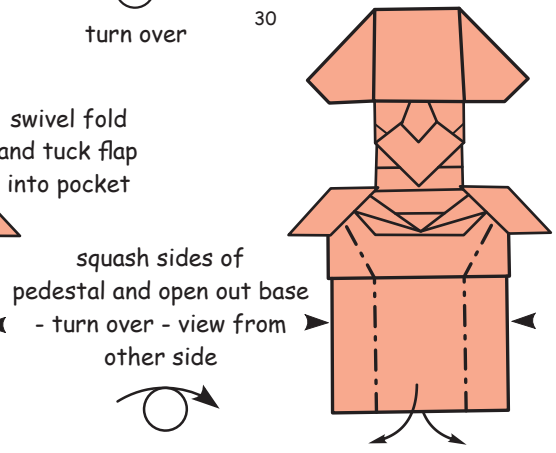

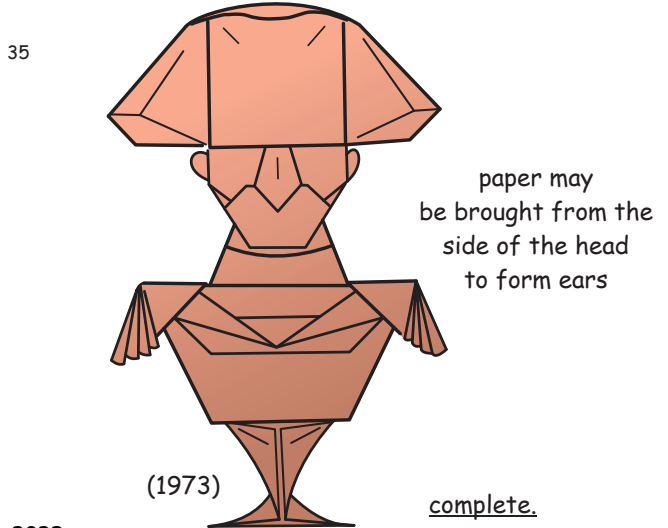
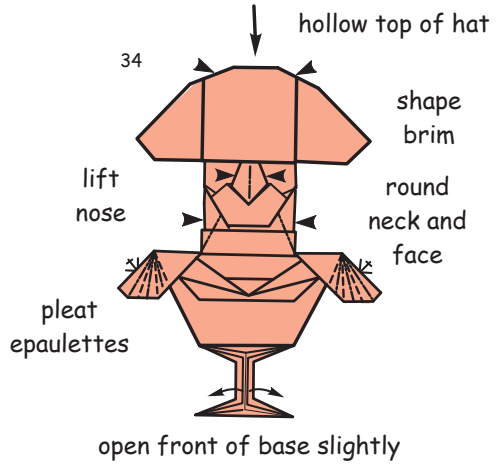
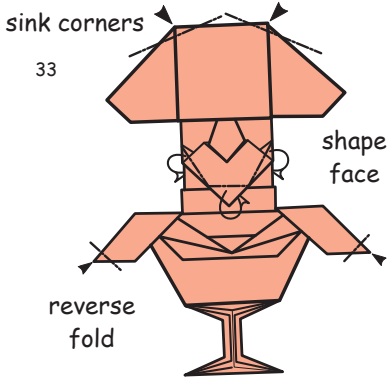
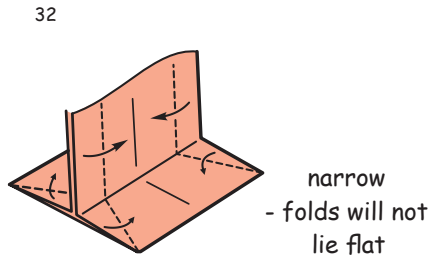
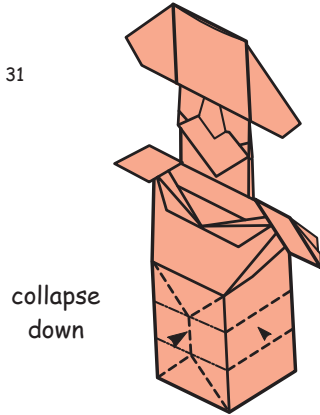

All rights reserved.

Model © Neal Elias 1970

Illustrations © Dave Venables 2023

Exercise 11

Construction of Nose for Busts Part I

1

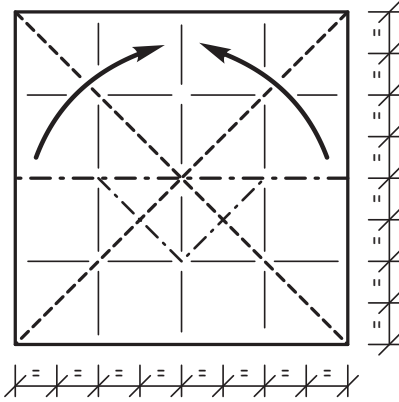

fold a waterbomb base

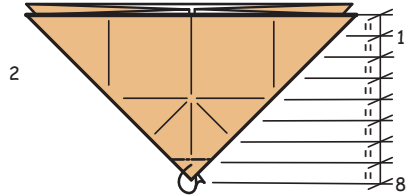

mountain fold $1/8^{\text{th}}$ behind

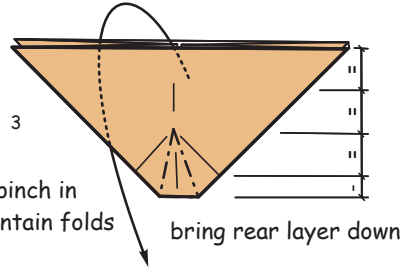

4

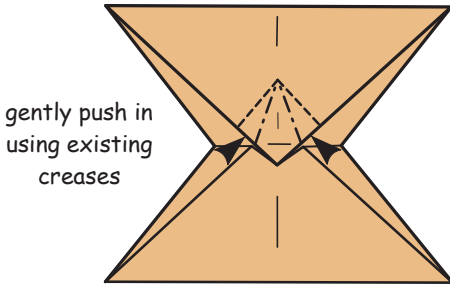

turn over

5

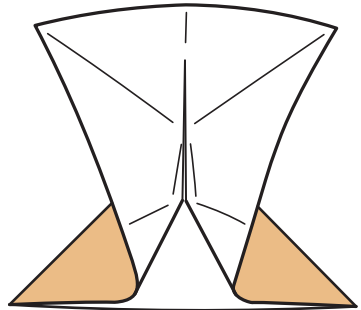

turn over

6

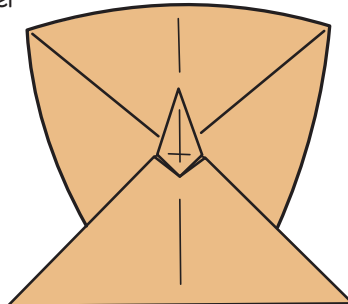

the model is convex
and will not lie flat

part I complete.

All rights reserved.

Model © Neal Elias 1970

Illustrations © Dave Venables 2023

Exercise 12

Forming the Nose (and Chin) on Busts Part II

Begin with a square of stiff crisp paper about 120 gsm

1

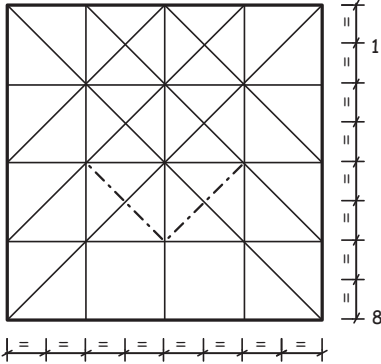

pre-crease as shown with valley folds with the exception of two short diagonal mountain folds.

Now fold the nose as in exercise 11 - Construction of Nose for Busts - Part I

2

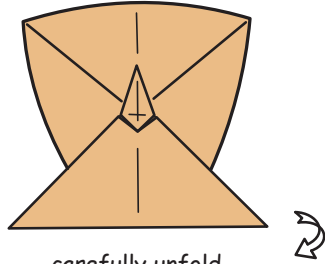

3

carefully unfold

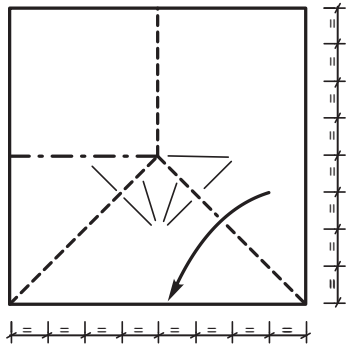

rabbit ear
(additional creases not shown)

4

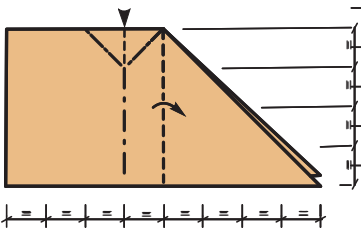

pleat both sides of flap sinking top

5

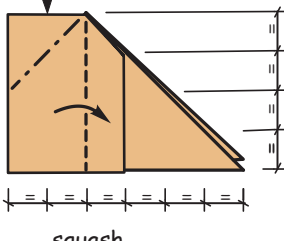

snatch

6

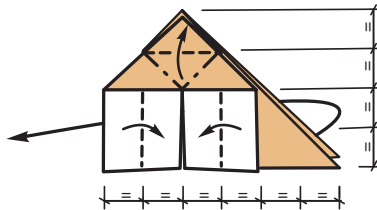

petal fold

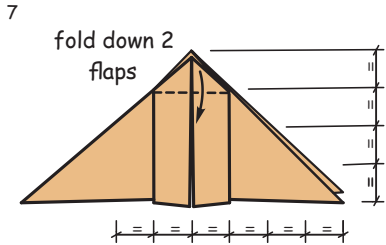

8

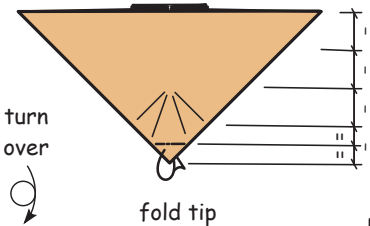

fold tip behind
bring all rear layers down

9

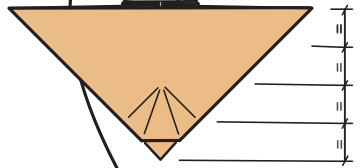

10

Pinch in the mountain folds either side of the nose squashing between the mountain (the valley is existing crease), thus re-constructing the nose made earlier

model is now 3D

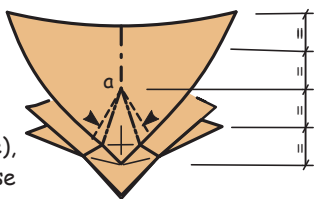

11

View from the side.

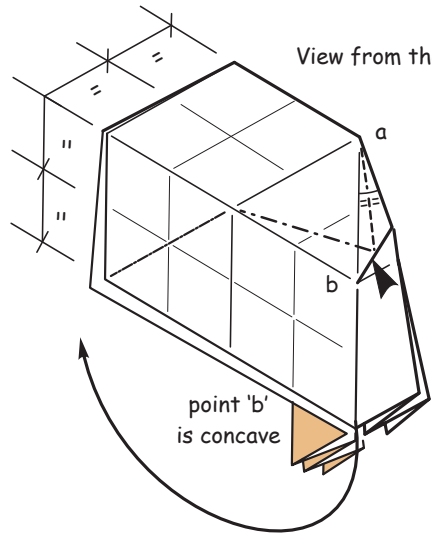

make new creases - the new valley bisects angle between existing edge and crease - bring the pleated section to the top of the model

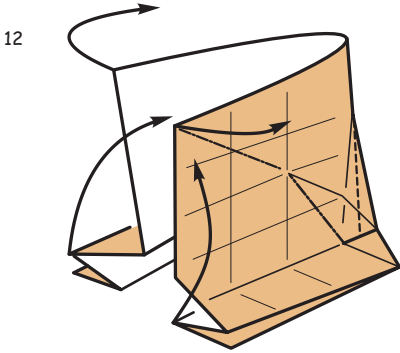

same move as previous
from a different perspective

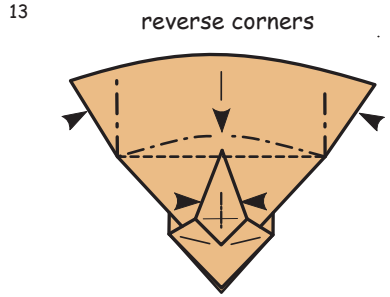

push in the brow
the angle of these folds
will vary from model to model

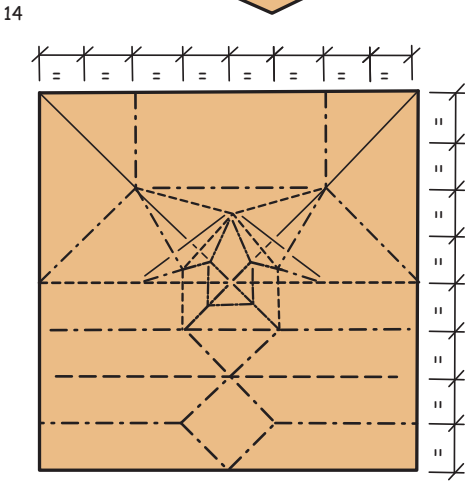

crease pattern for head

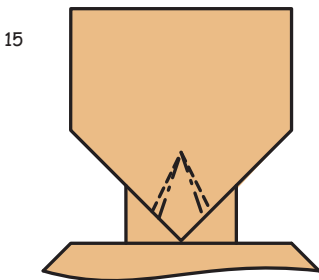

the brow does not lie flat to the model

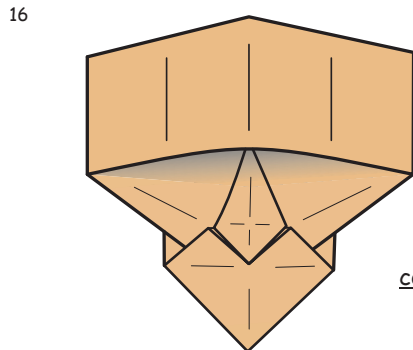

complete.

All rights reserved.

Model © Neal Elias 1970

Illustrations © Dave Venables 2023