

Use a square of pink paper, colored side up. Fold the top and bottom edges together and open up.

1. Fold the right edge to the left.
2. Fold the bottom edge to the left edge and return.
3. Reverse fold point A on a line one third of the way between the diagonal crease made in step 2 and point A.

4. Fold the vertical edge to the diagonal crease and return.
5. Now fold over the upper layer and flatten at top right as shown in steps 6-8 of Basic Mask 4 (p. 51) . . .
6. . . . like this. Then continue as in steps 2-12 of Basic Mask 5 (p. 55).

**DR.  
SCHWEITZER**

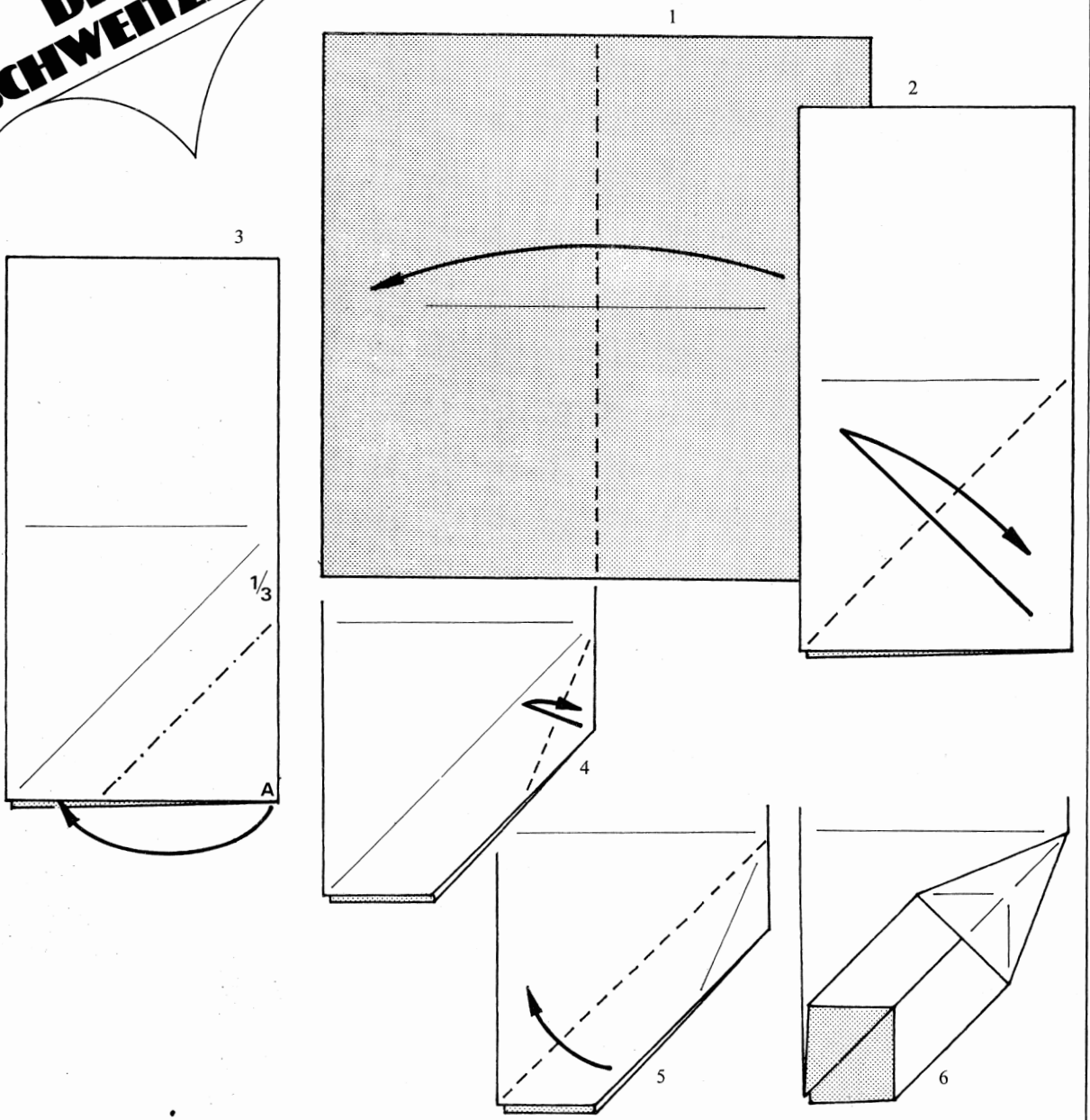

- 7. Step 6 completed. Turn over.
- 8. Bring the upper layer over in a squash fold. Watch point X. Rotate the model to new position.
- 9. Fold up the horizontal edge as far as it will go.
- 10. Then fold it down to the base of the nose.

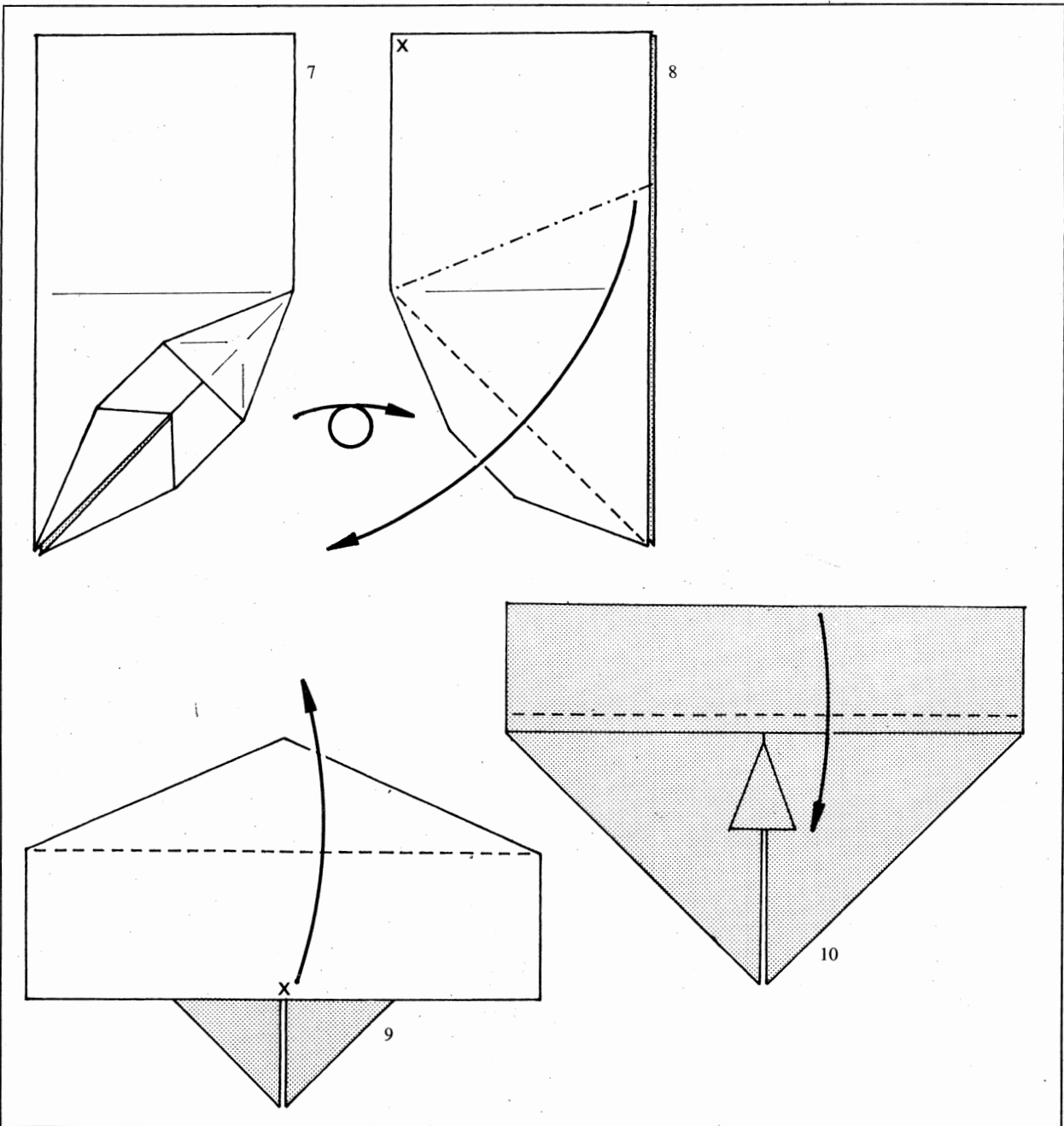

11. Mountain fold the front flap in half (or raise the flap, valley fold to the crease and close). Turn over.

12. Fold the right side across the edge of the center flap.

13. Now squash this flap so that the existing crease lies on the vertical edge.

14. Swivel the pleated area to the right.

15. Mountain fold and tuck in.

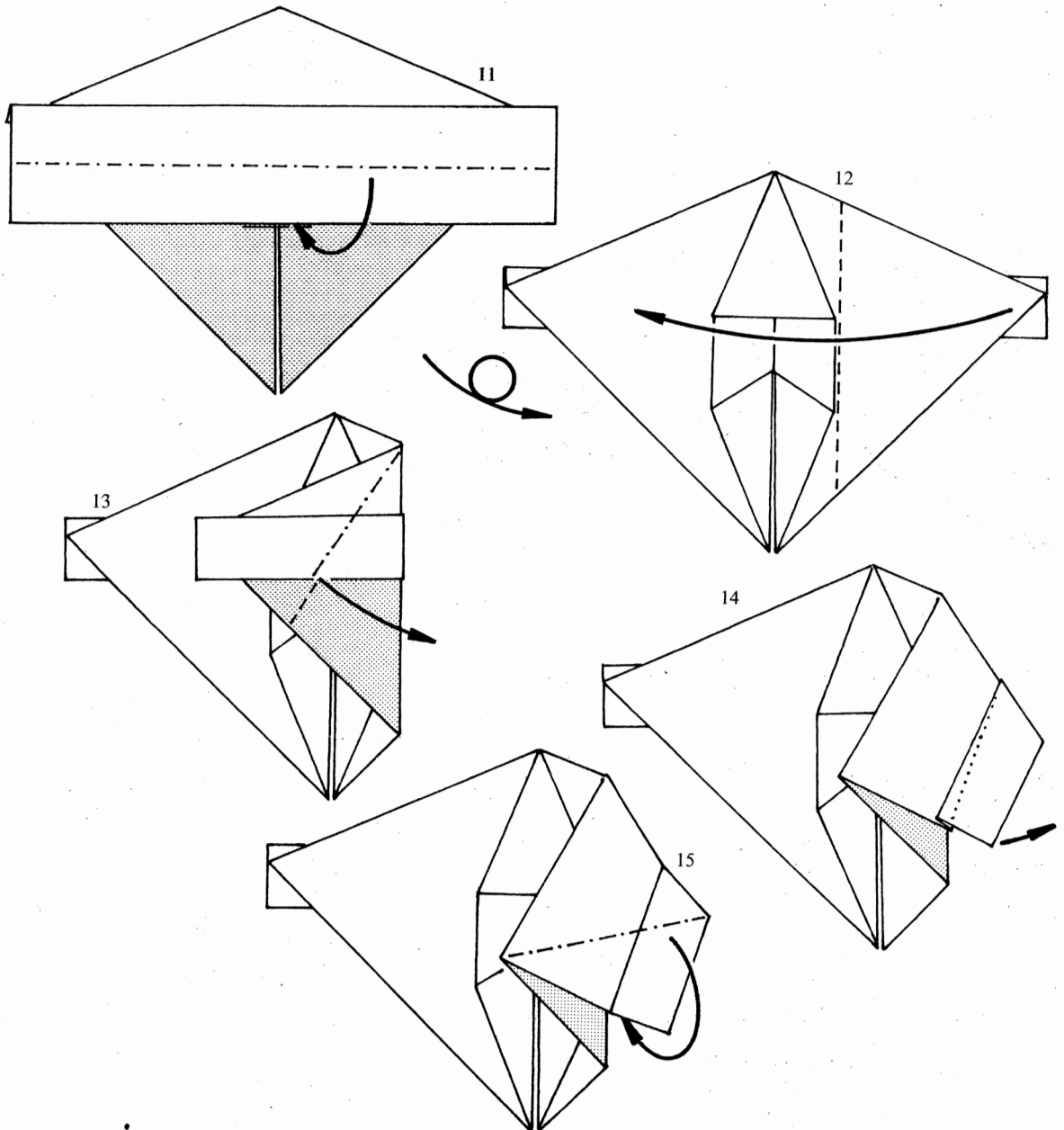

16. Mountain fold on the center line.

17. Pull the concealed right center flap to the front. Then mirror steps 12-17 at left . . .

18. . . . to reach this result. Turn over.

19. To form the moustache, continue as in steps 10-15 of Stalin (p. 59).

20. Dr. Schweitzer completed.

