

# Dragon Rampant

Xabier Sevillano (IG: @xevi6960)

Recommended size: 8 x 8 in

Two-colour paper: no

Difficulty: intermediate

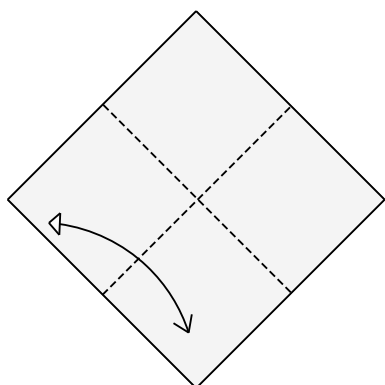
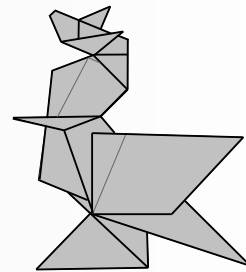

1. Fold and unfold

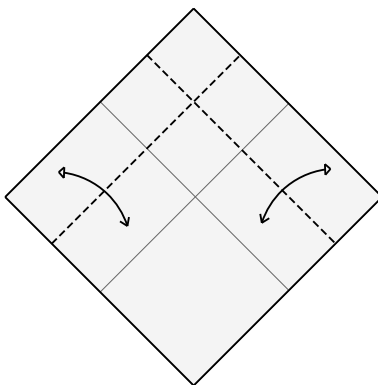

2. Fold and unfold

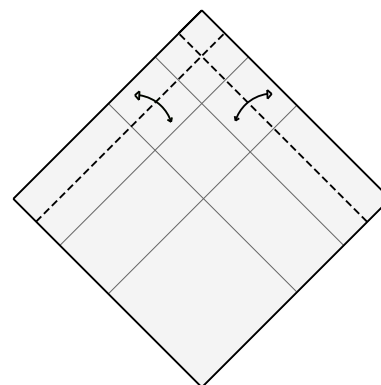

3. Fold and unfold

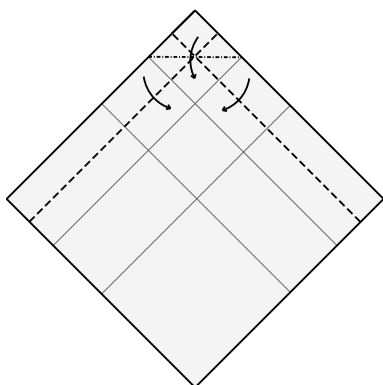

4. Collapse  
(displaced preliminary base)

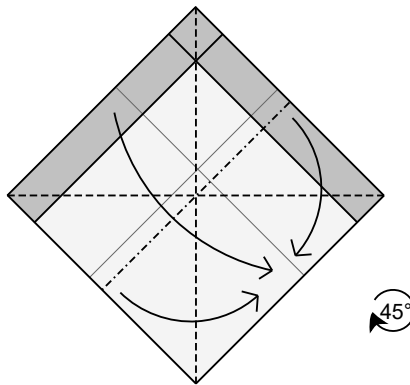

5. Fold a waterbomb base

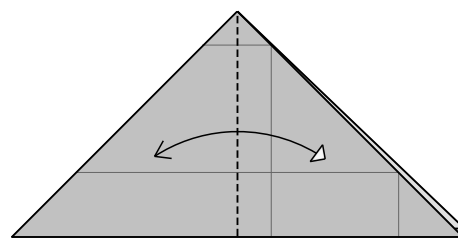

6. Fold and unfold

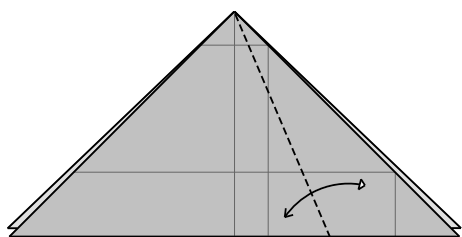

7. Fold and unfold

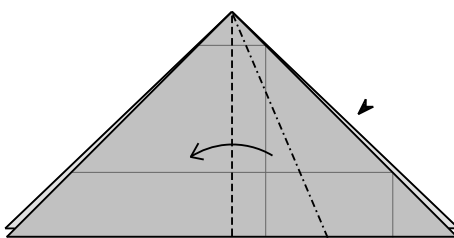

8. Squash fold

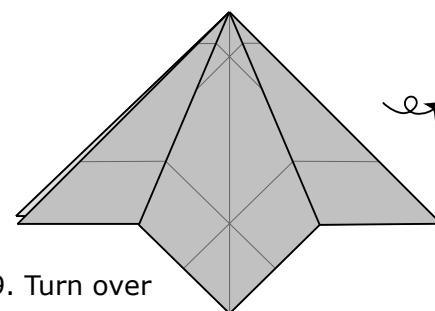

9. Turn over

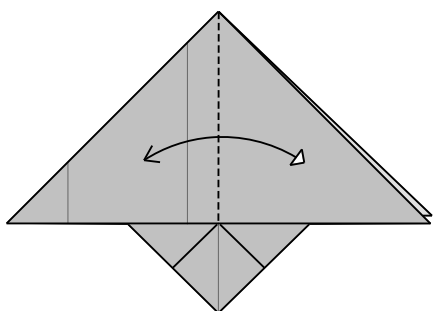

10. Fold and unfold

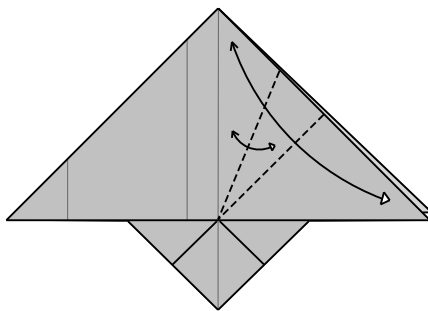

11. Fold and unfold

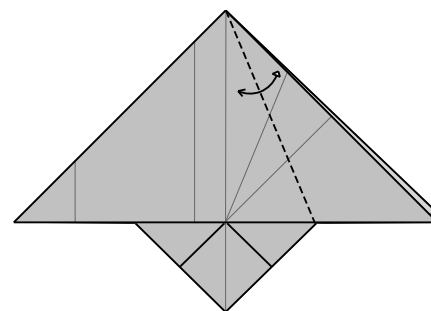

12. Fold and unfold

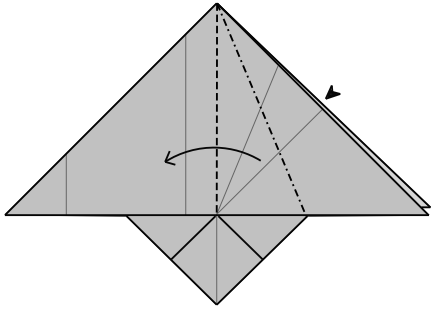

13. Squash fold

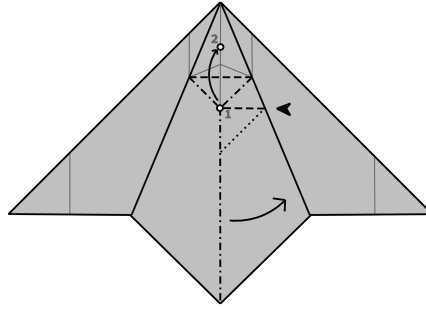

14. Collapse to one side

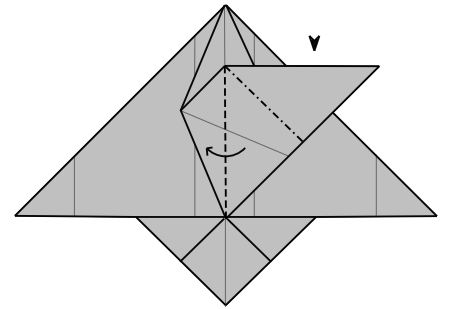

15. Squash fold

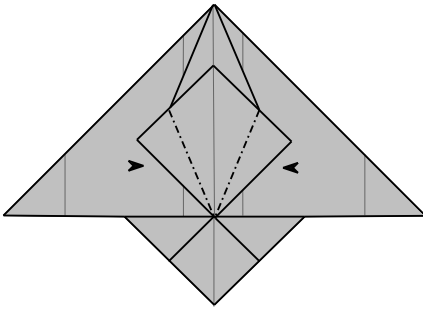

16. Push in

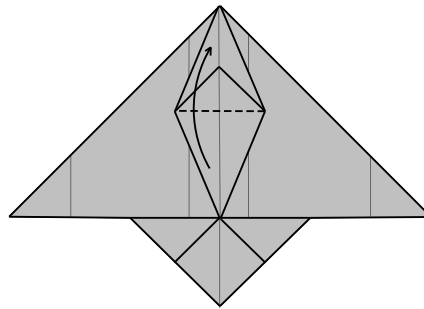

17. Valley fold

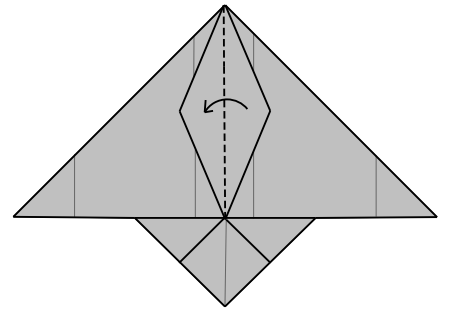

18. Valley fold (two layers)

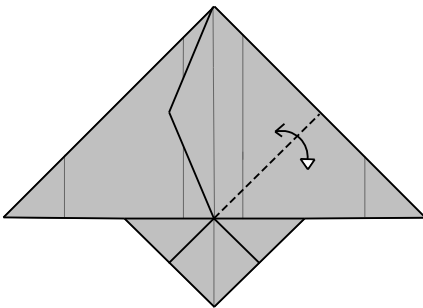

19. Fold and unfold

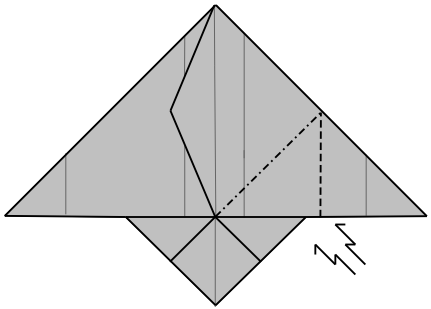

20. Crimp fold

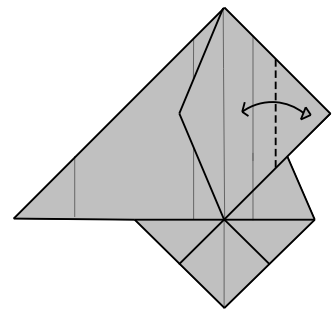

21. Fold and unfold

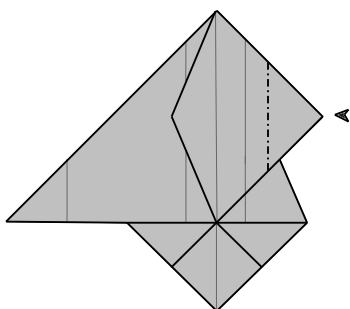

22. Open sink fold

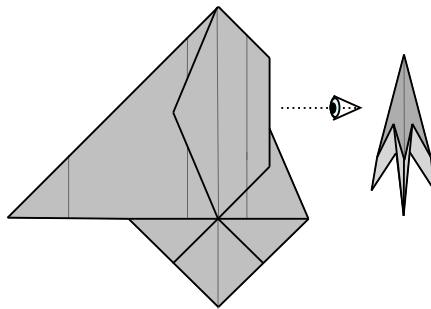

23. Side view of step 22

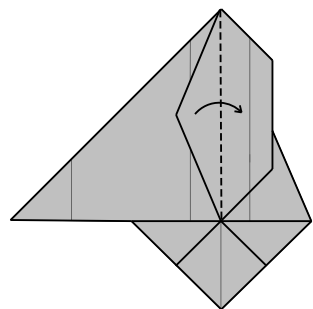

24. Valley fold (two layers)

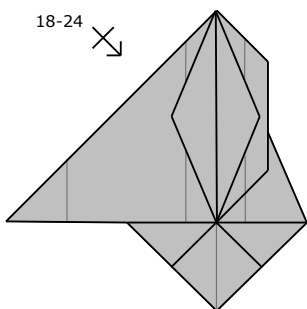

25. Repeat steps 18 to 24 on the other side

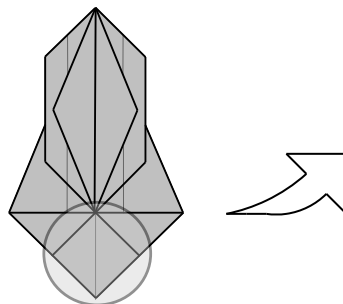

26. Enlarged view of the head

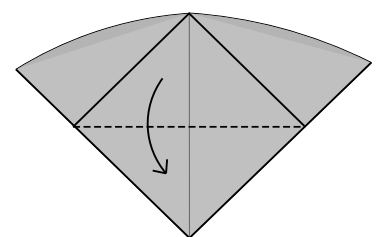

27. Valley fold

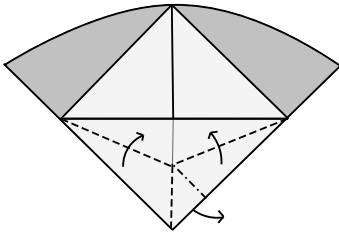

28. Rabbit ear fold

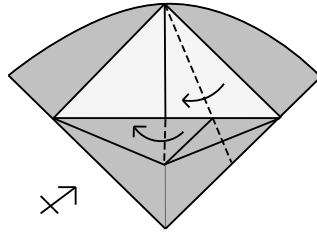

29. Valley fold, leaving the point out

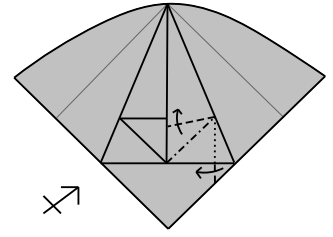

30. Swivel fold

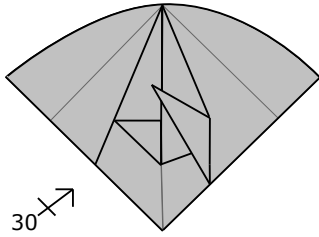

31. Repeat step 30 on the other side

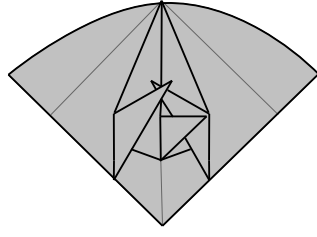

32. Detailed head view

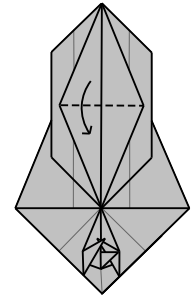
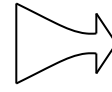

33. Valley fold

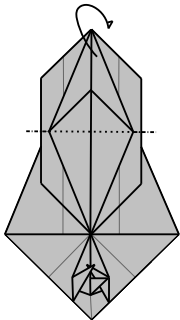

34. Mountain fold

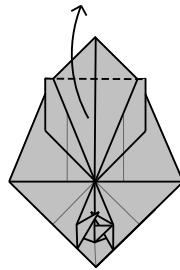

35. Valley fold (three layers)

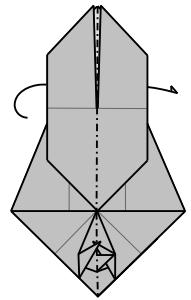

36. Mountain fold. Rotate

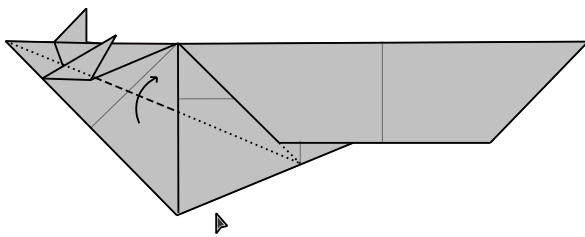

37. Swivel fold, leaving out the head

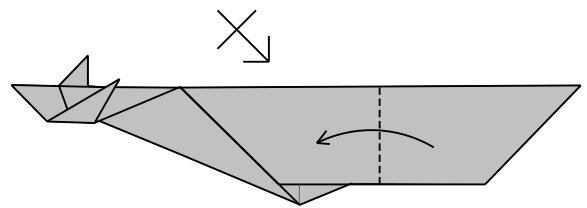

38. Valley fold (one layer)

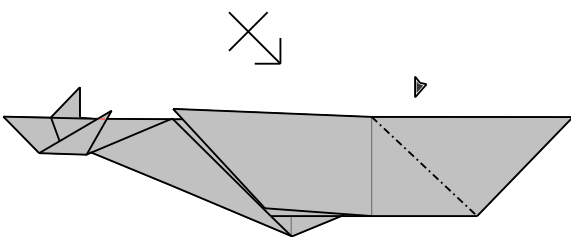

39. Inside reverse fold

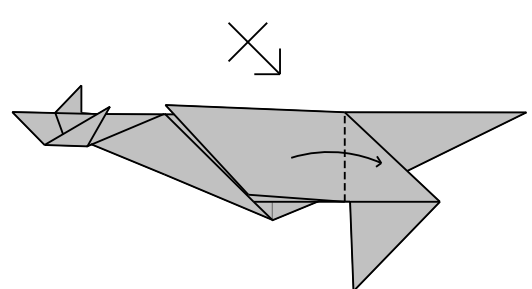

40. Valley fold

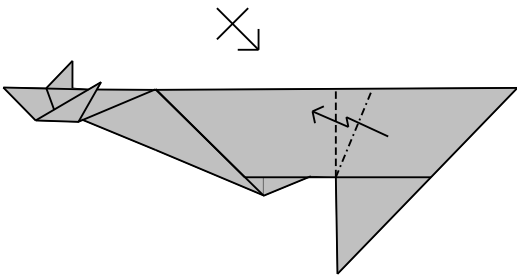

41. Zig-zag fold

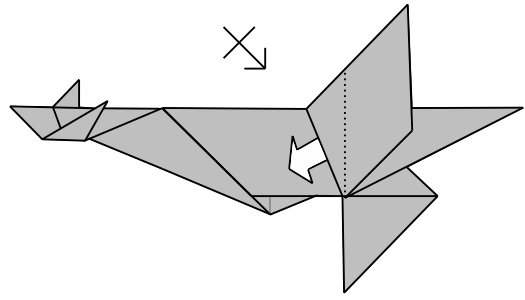

42. Pull out paper

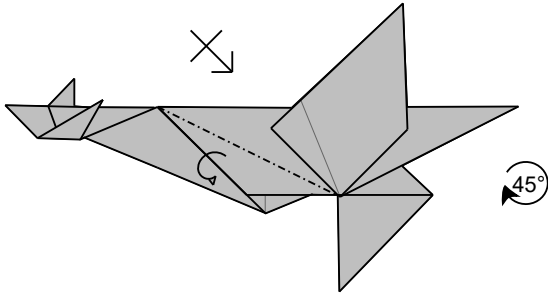

43. Mountain fold. Rotate

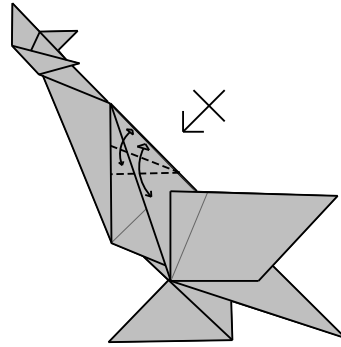

44. Fold and unfold.

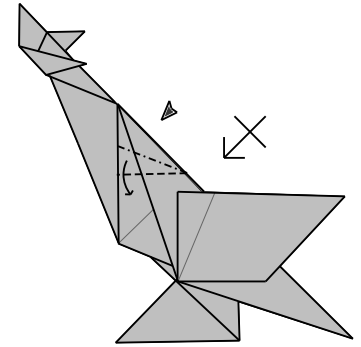

45. Squash fold.

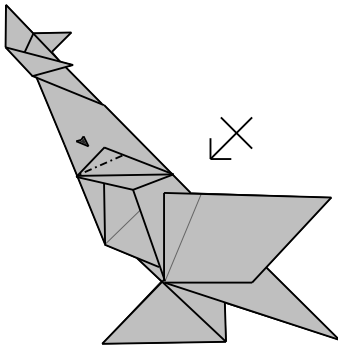

46. Push in.

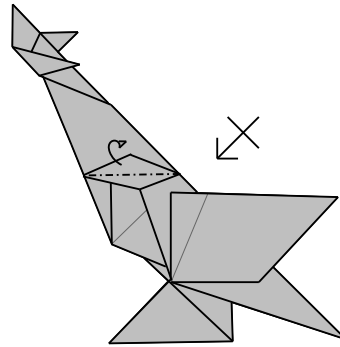

47. Mountain fold.

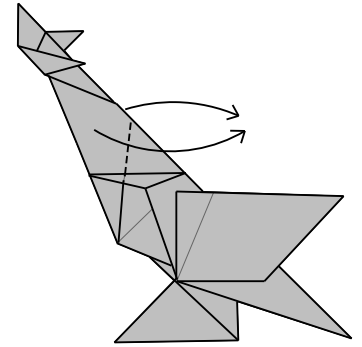

48. Outside reverse fold

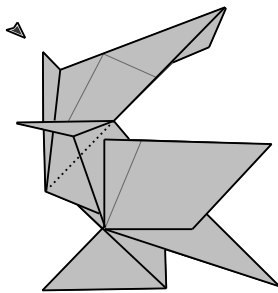

49. Hide the inner point

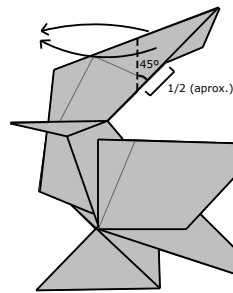

50. Outside reverse fold

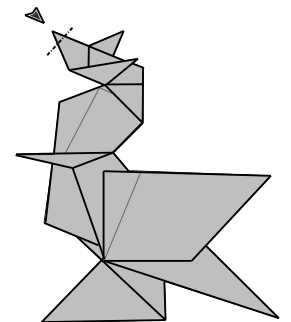

51. Hide the nose point

