

SWAN

Steve De Clercq

07/2023

Medium to thick paper 20x20 cm

For wetfolding:

Arches 300gsm 30x30 cm

square cut diagonally in half

Use same color on both sides

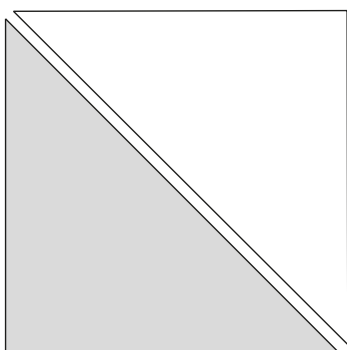
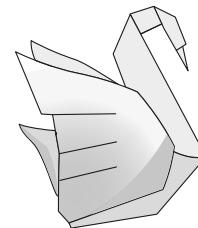

1 - Cut square in half

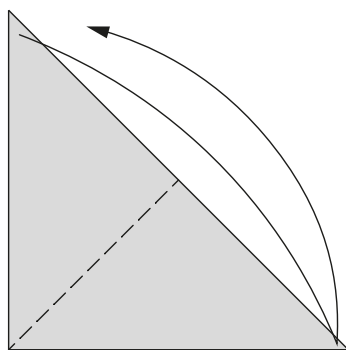

2

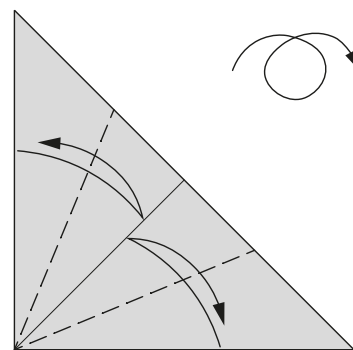

3

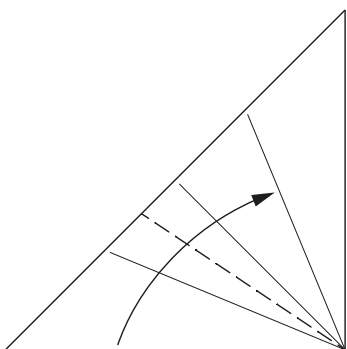

4

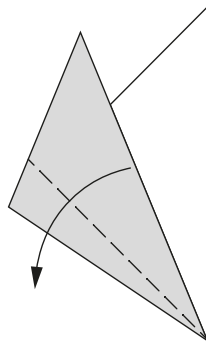

5 - Fold along existing crease

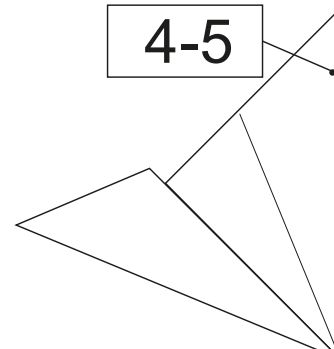

6

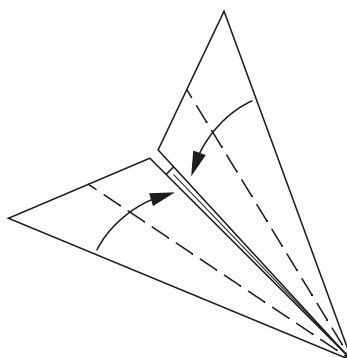

7

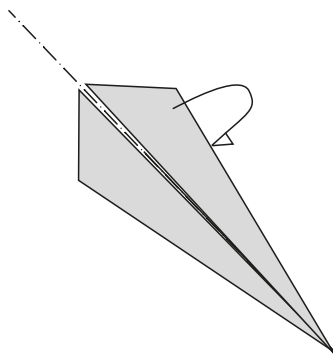

8

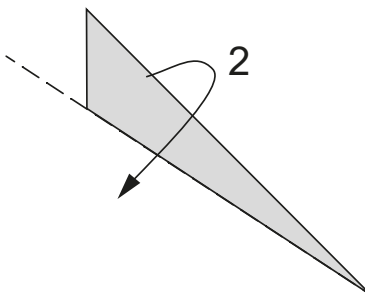

9 - Fold down 2 layers

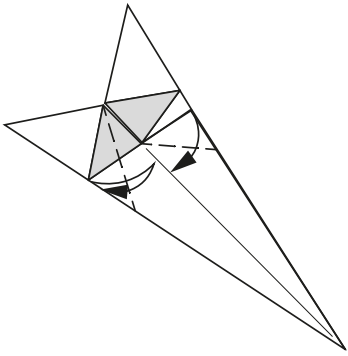

10

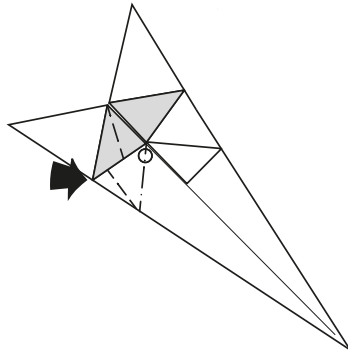

11 - Inside reverse fold. Notice the shifted mountain fold.

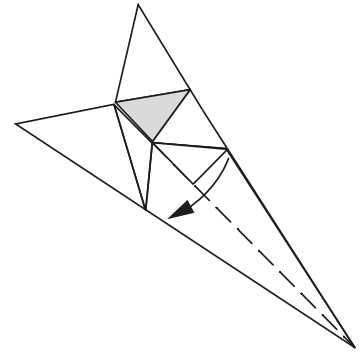

12

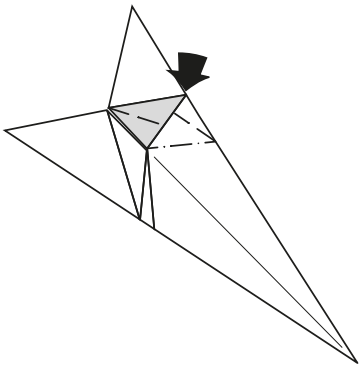

13 - Inside reverse fold (precrease like step 10)

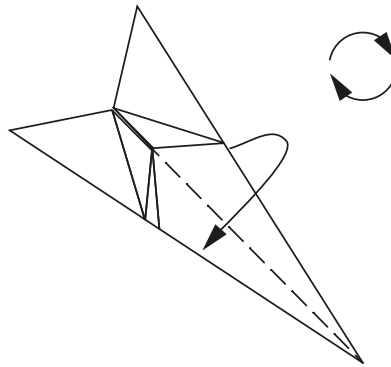

14 - Fold whole model in half

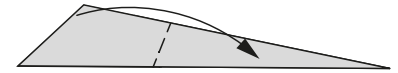

15 - Fold top as far as possible, bottom not as far, see next step for reference

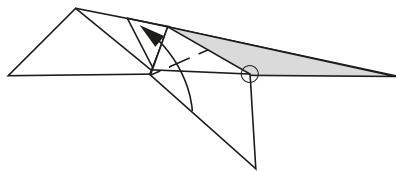

16 - Notice reference for previous step, see next step for result

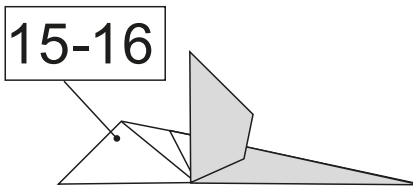

17

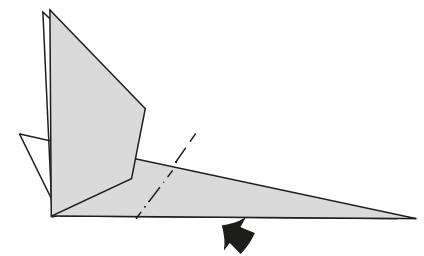

18 - Inside reverse fold, no reference

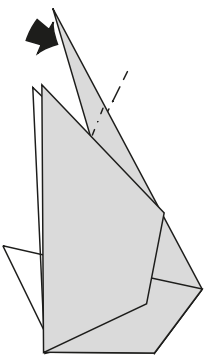

19 - Inside reverse fold, no reference

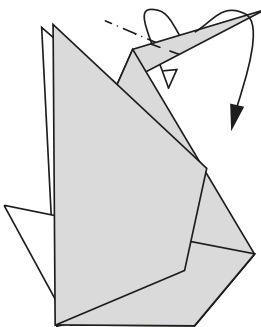

20 - Outside reverse fold, no reference

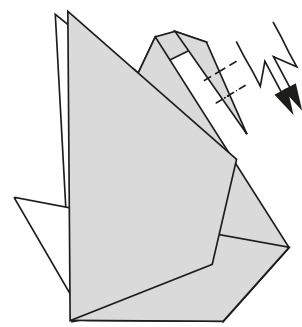

21 - Double crimp inside

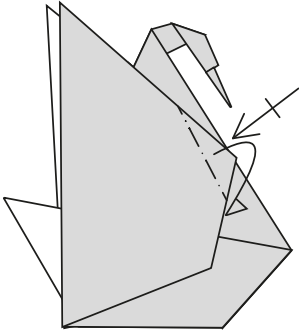

22 – No reference, repeat on backside

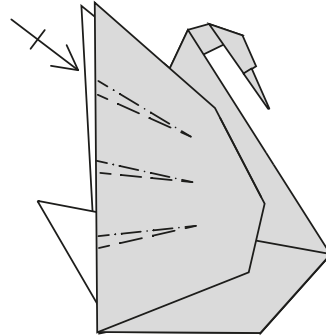

23 – Crimp as wanted, repeat on backside, shape

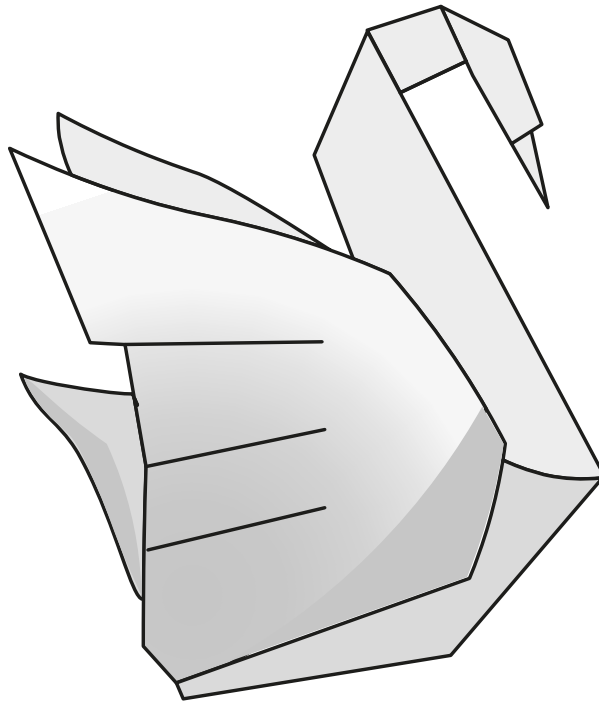

24 – Finished!