

Timber the Dog

John Szinger

A loyal and friendly companion, Timber is a dog in a sitting posture. It is an intermediate model with emphasis on the sculptural qualities. Varying the proportions can yield a variety of appearance in the final form. I recommend using larger, thicker paper such as Tant or Canson.

Recommended paper: 10" square or larger. Begin with a square, white side up.

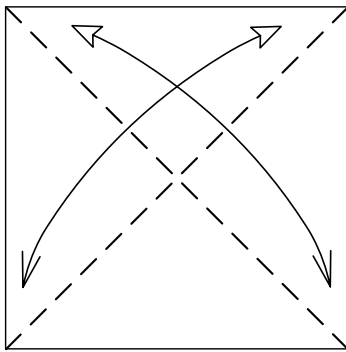

1. Fold and unfold on the diagonals.

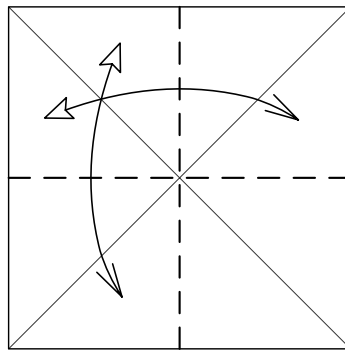

2. Fold and unfold on the square axes.

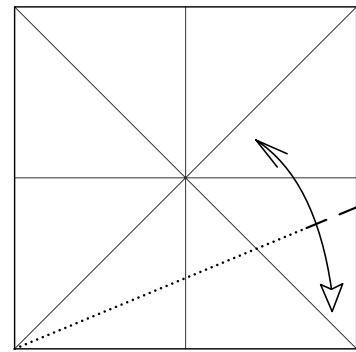

3. Valley fold the edge to the centerline. Crease only at the edge. Unfold.

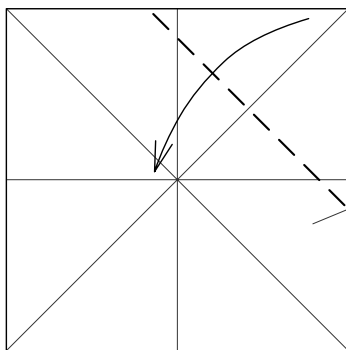

4. Valley fold the corner at the mark.

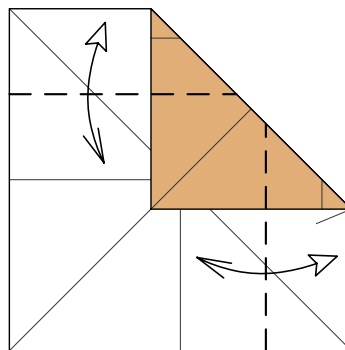

5. Fold two edges to the centerline and unfold.

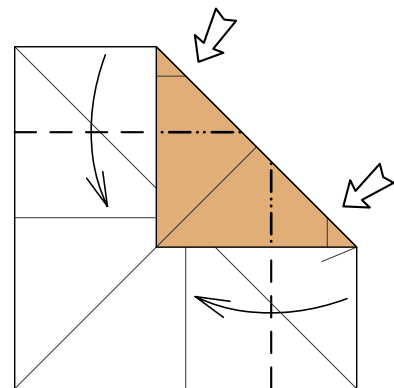

6. Reverse folds.

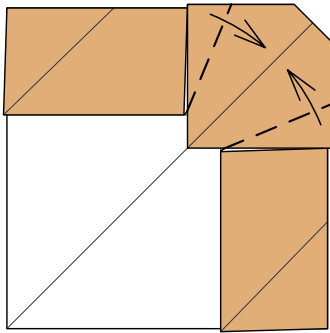

7. Fold the flaps toward the middle.

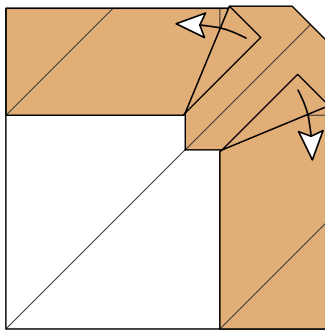

8. Unfold.

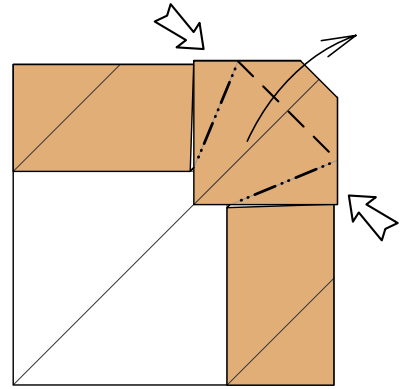

9. Petal fold.

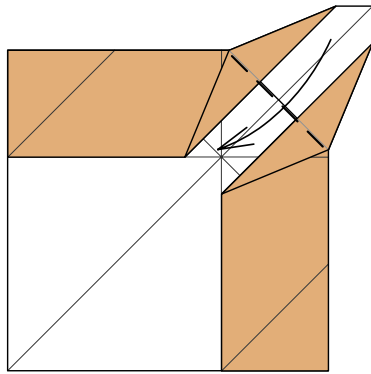

10. Fold the flap back down.

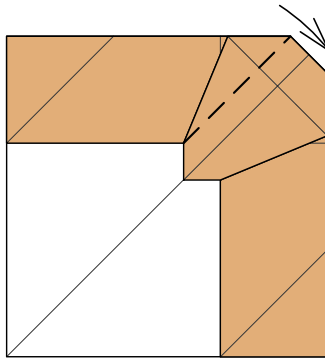

11. Swing the flap to the right.

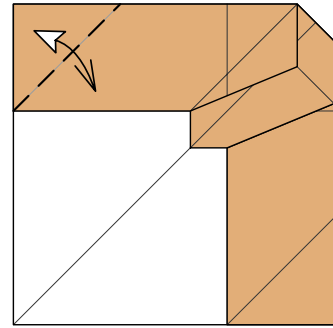

12. Fold and unfold.

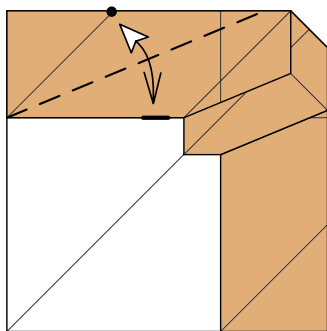

13. Fold and unfold.

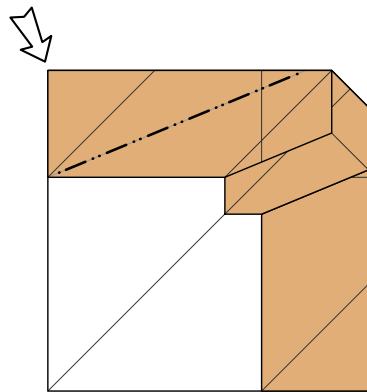

14. Reverse fold.

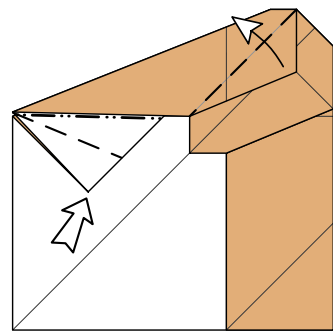

15. Reverse fold in and out again. Swing the flap back to the left.

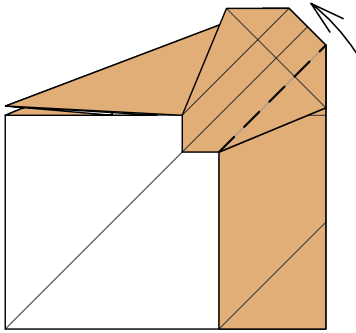

16. Repeat step 11 – 15 on the other side.

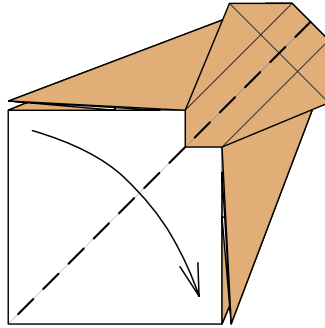

17. Fold the model in half.

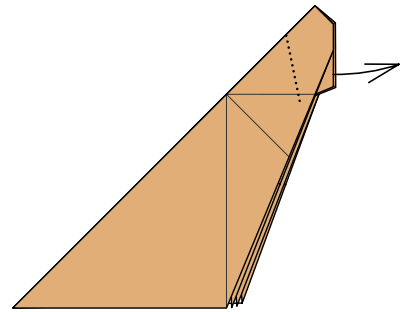

18. Reverse fold a hidden flap.

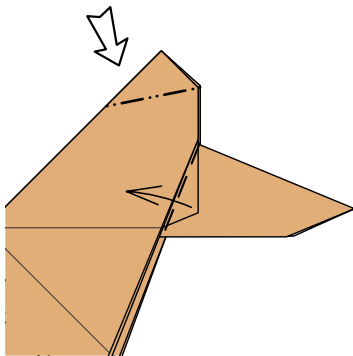

19. Zoom in view on the head. Reverse fold at the top. Fold a flap back, repeat behind.

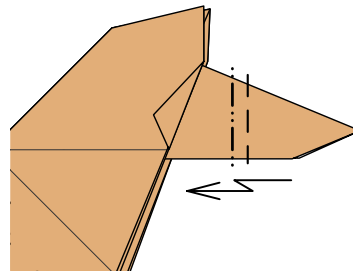

20. Crimp the snout.

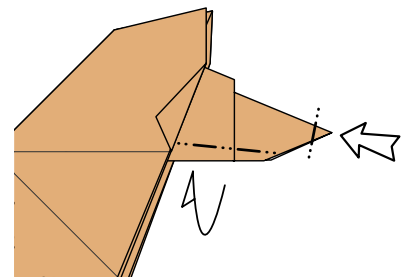

21. Reverse fold the nose. Tuck a layer underneath, repeat behind.

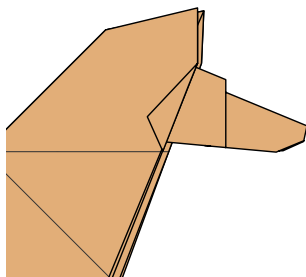

22. The completed head.

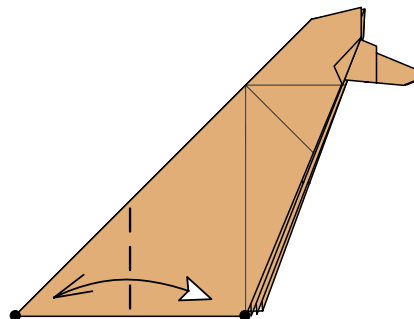

23. Fold and unfold.

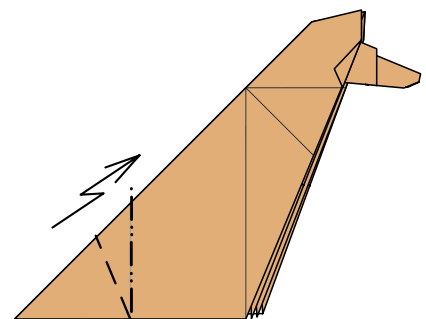

24. Crimp.

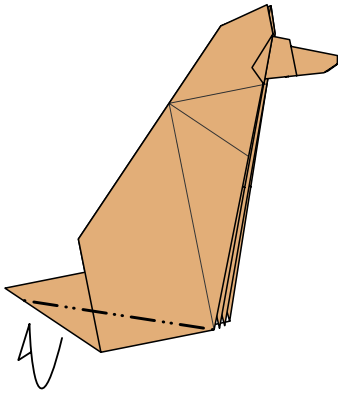

25. Tuck a layer underneath, repeat behind.

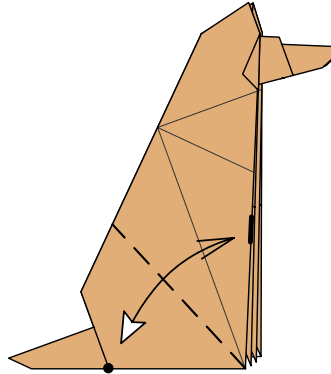

26. Fold and unfold.

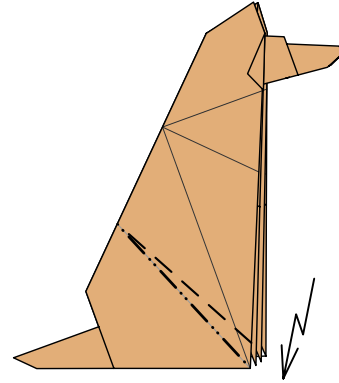

27. Crimp.

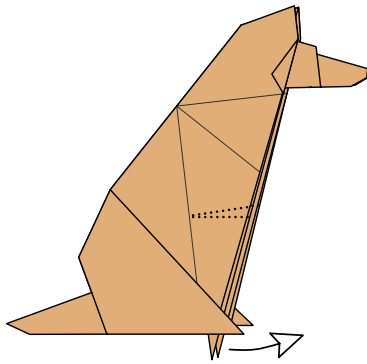

28. Swing the front legs out and flatten.

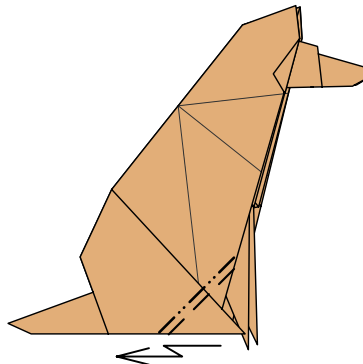

29. Crimp, repeat behind.

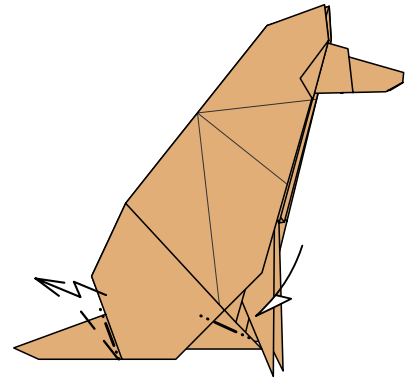

30. Crimp the tail. Thin the hind foot, repeat behind.

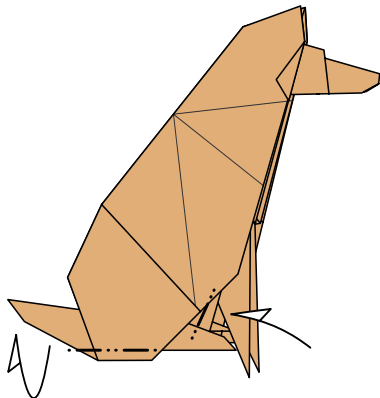

31. Tuck in a layer at the bottom, repeat behind. Swivel fold to hide some paper on the hind leg, repeat behind.

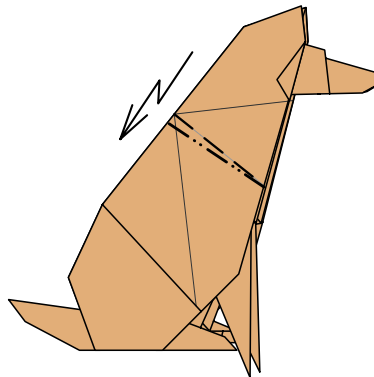

32. Crimp at the neck.

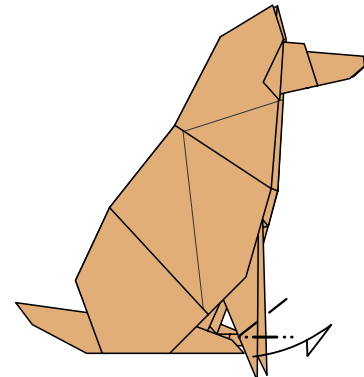

33. Squash fold the front leg.

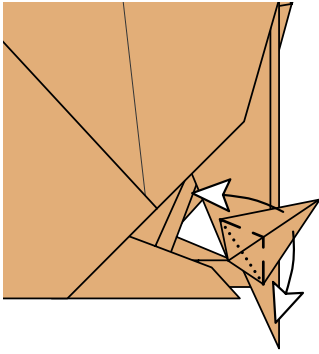

34. Zoom in view of the front paw. Spread the tip and flatten.

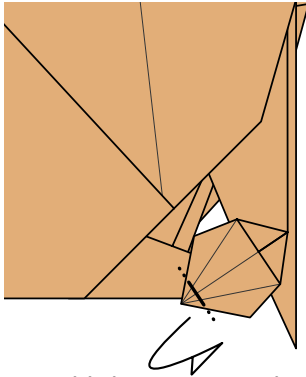

35. Fold the corner underneath.

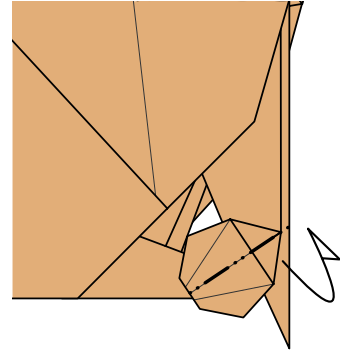

36. Fold behind.

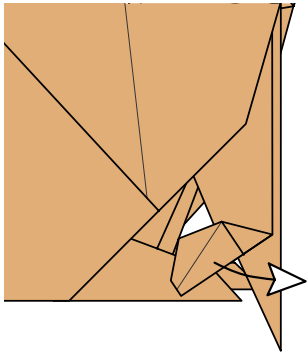

37. Swing the paw forward and flatten.

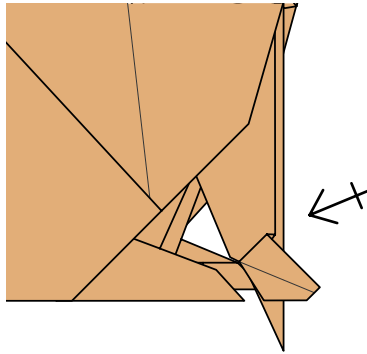

38. Repeat steps 34 – 37 on the other paw.

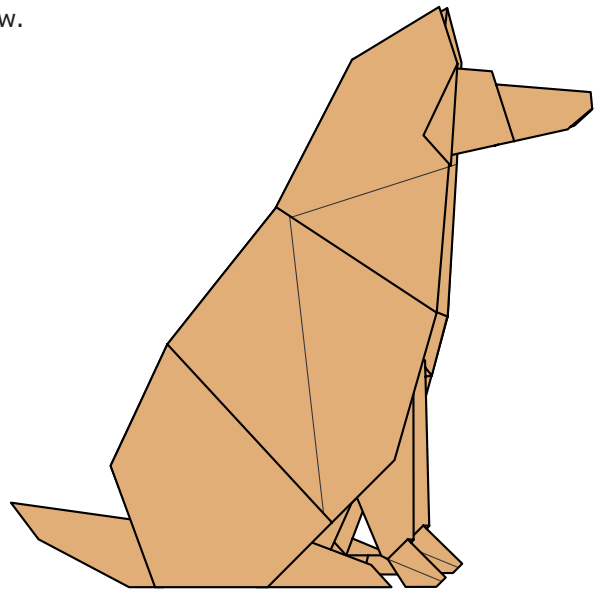

39. Timber the dog.