

1

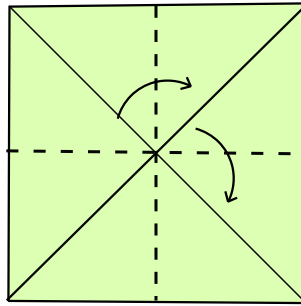

2

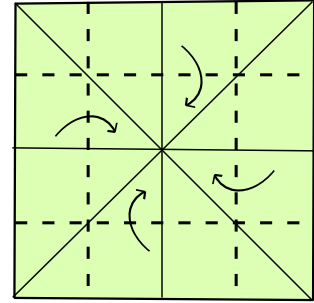

3

Doblar por la mitad y aplanar por el centro

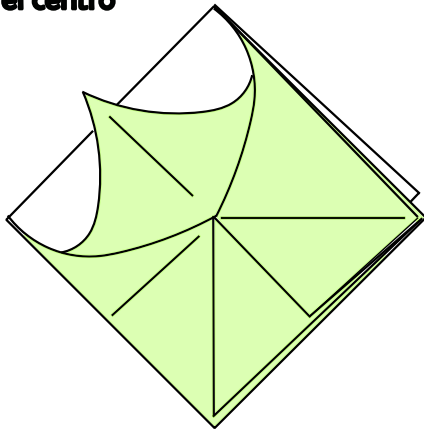

4

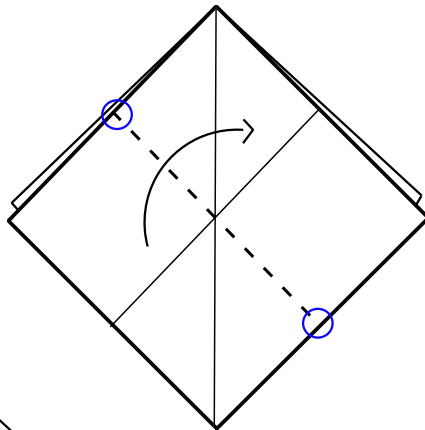

5 Base preliminar

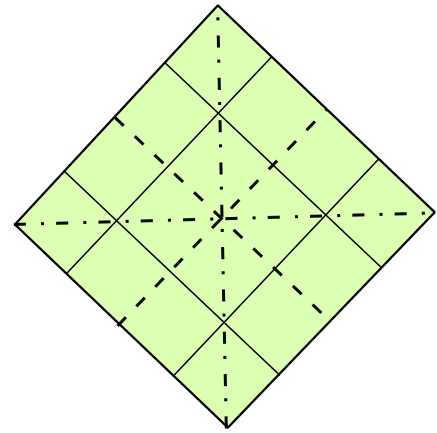

6

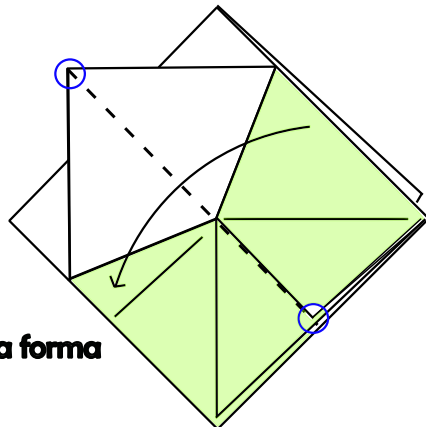

Regresar la forma inicial

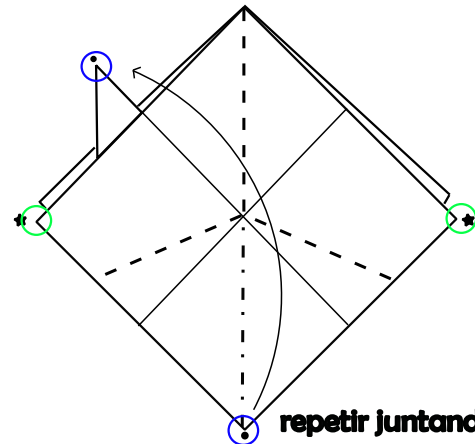

7



8

repetir juntando las puntas con  para llevar la punta  a la izquierda



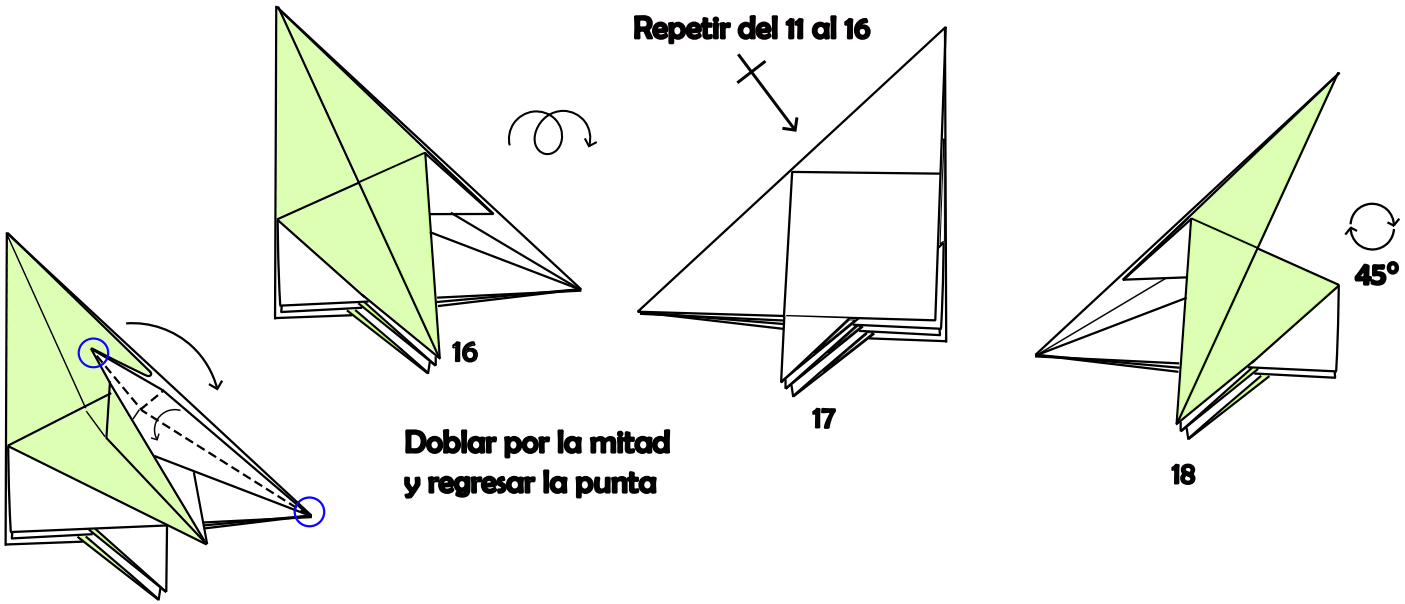

Repetir del 11 al 16

Doblar por la mitad y regresar la punta

15
Levantando un poco la punta para doblar por la mitad

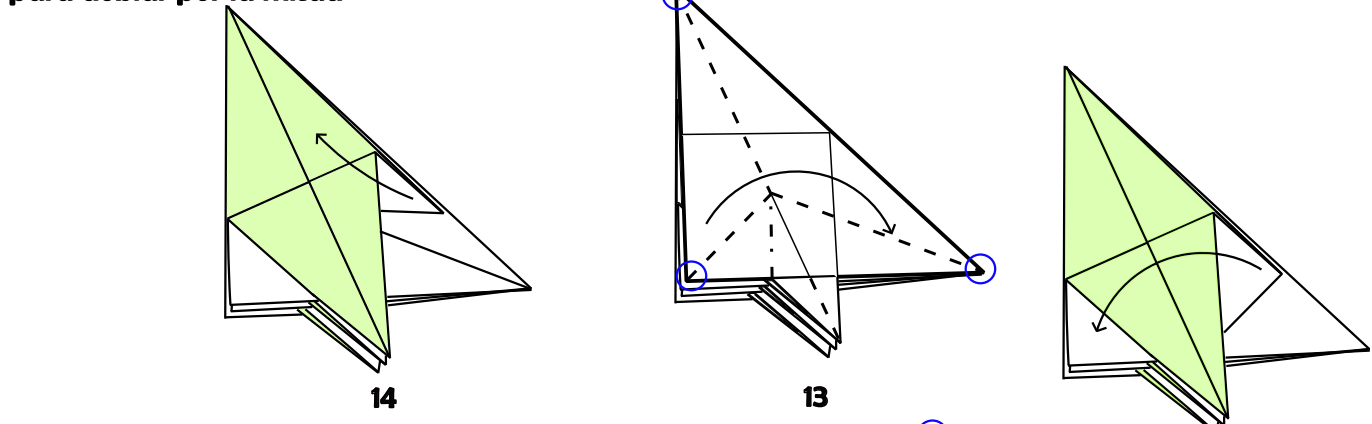

12
Doblar y desdoblar

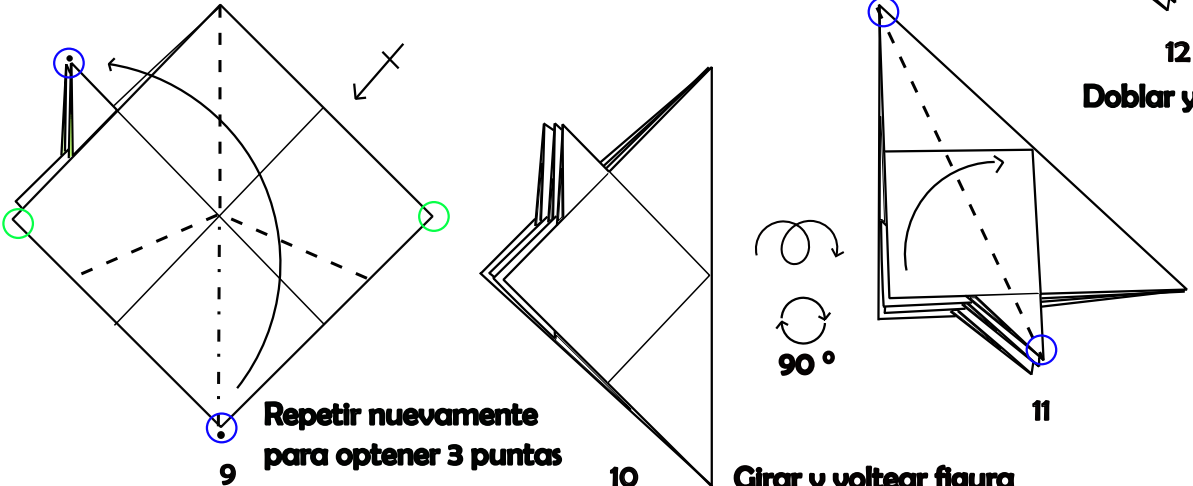

9
Repetir nuevamente para obtener 3 puntas

90°

Girar y voltear figura

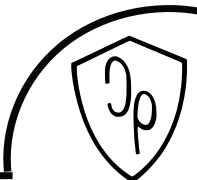

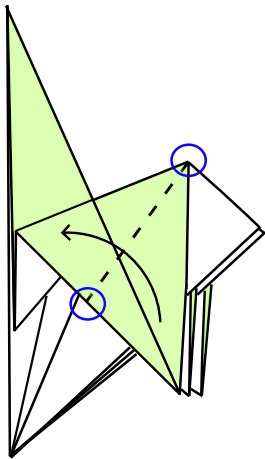

19

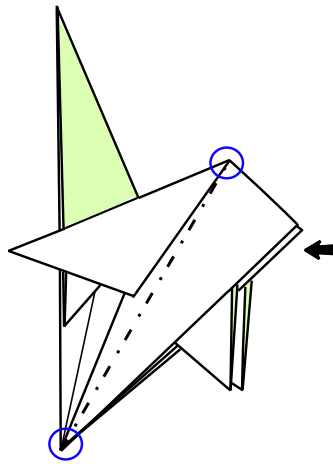

20
Hundir la punta en valle
hacia dentro

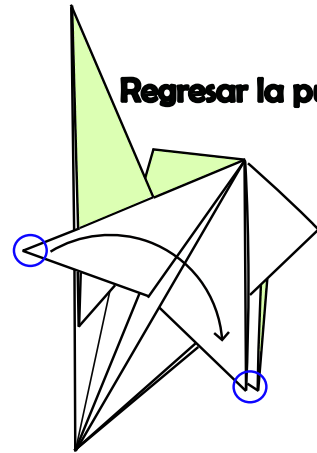

Regresar la punta

21

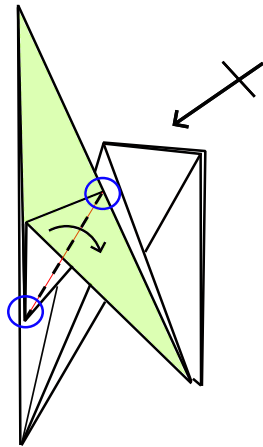

Repetir 19 al 21

22

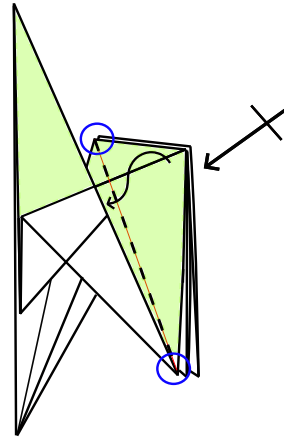

23
Doblar y meter en la
primera capa y repetir
lado contrario

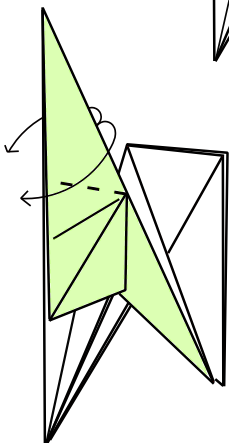

24

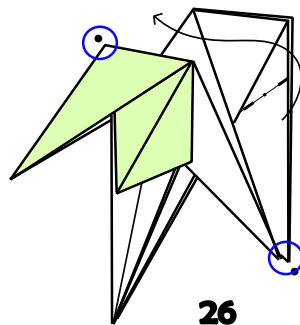

25
Doblez inverso
hacia afuera

26

Doblez inverso
hacia dentro juntando
los ○

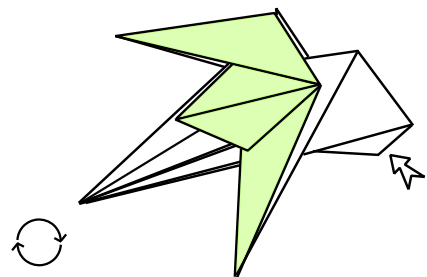

27

Abrir por el centro sin
aplanar, solo ver la punta
del centro y doblar



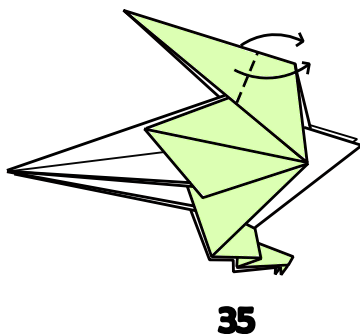

35

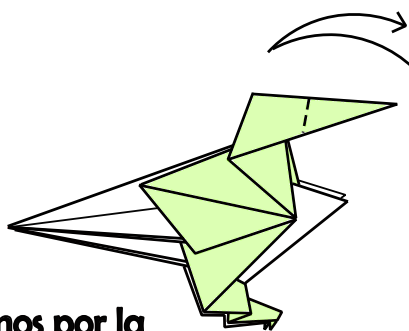

36

Marcamos por la mitad y regresamos

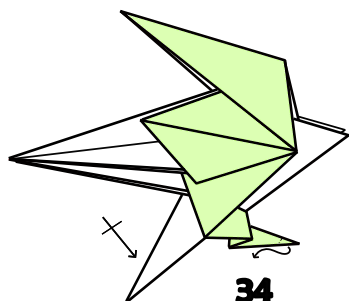

34

Repetimos del 31 al 34

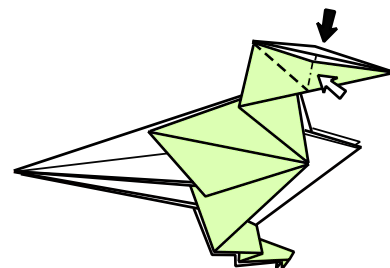

37

Hundimos la capa del centro y abrimos las 2 capas

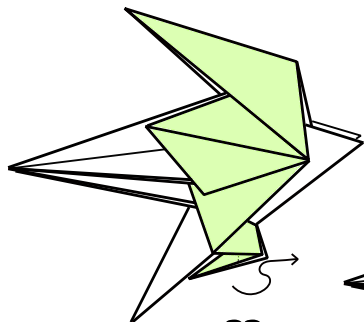

33

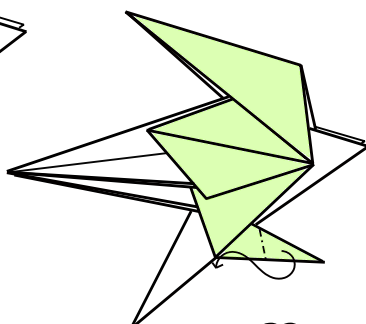

32

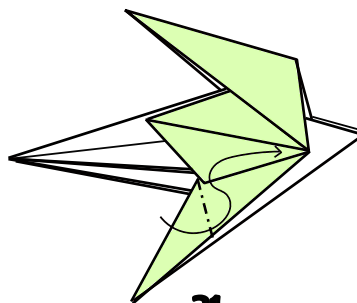

31

Marcamos para crear las patas

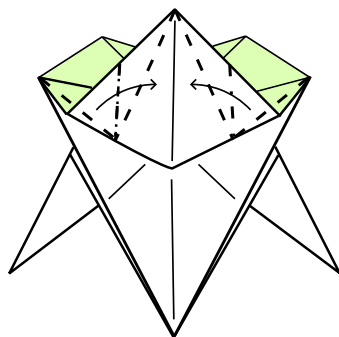

28

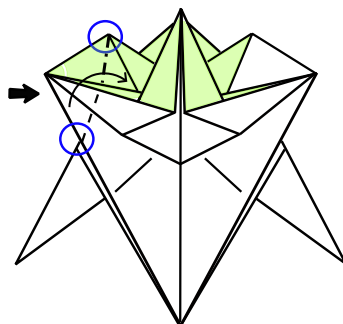

29

Hundir por atras de la punta

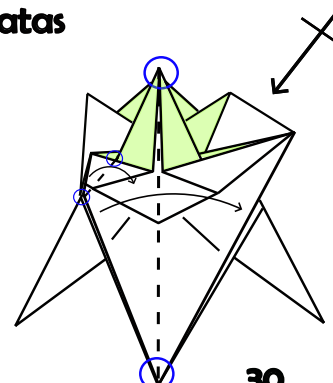

30

Repetir el lado contrario y doblar por la mitad

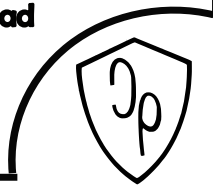

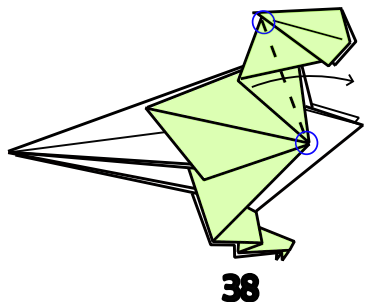

38

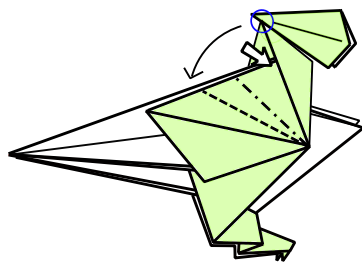

39

Liberamos la capa y jalamos hacia abajo sobre las líneas

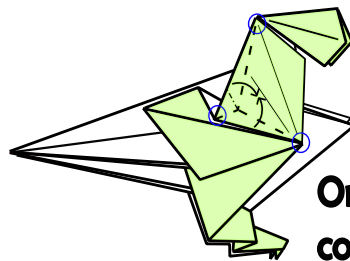

40

Oreja de conejo

Repetimos del del 38 al 43

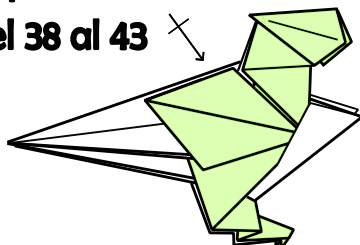

43

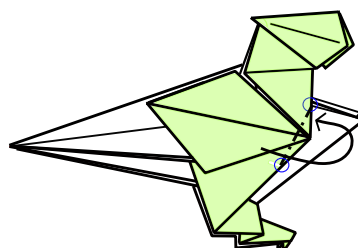

42

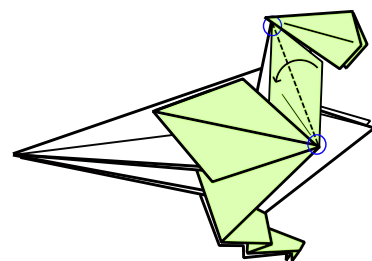

41

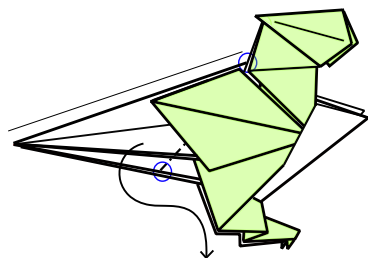

44

Desdoblar la cola

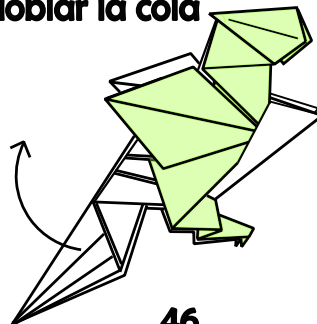

46

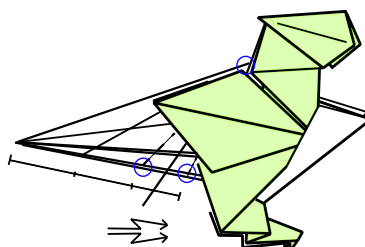

doblamos sobre sobre las líneas marcadas 47

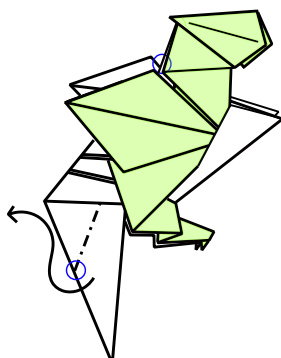

45



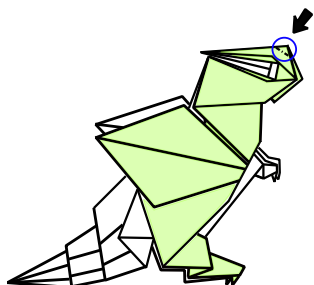

55

Repetir en el otro ojo



54

Marcar el ojo
doblado 1/3
del borde

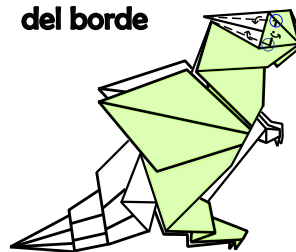

53

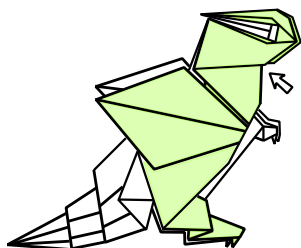

56
Sacar la punta para
la boca



Figura terminada

Abrir y aplanar
por el centro



52

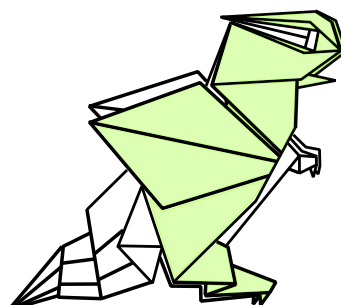
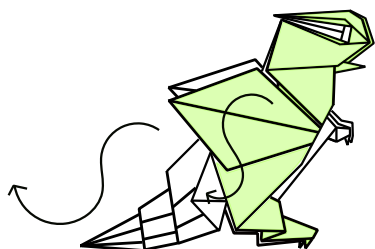

57
Modelar cola y alas
curvas

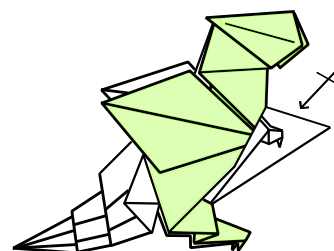

51
Repetir del 49 al 51

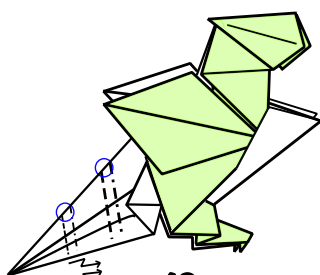

48
zig zag doble para
doblar la cola

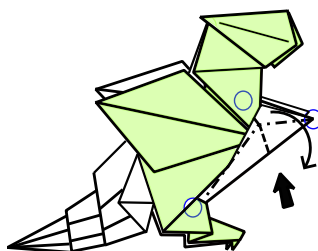

49
Oreja de conejo doble

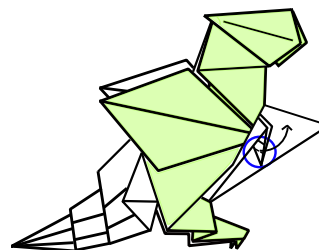

50
Subir y bajar el brazo



