

# SNOOPY

by Whitepaper (LEE IN KYUNG)

2024. 12. 29

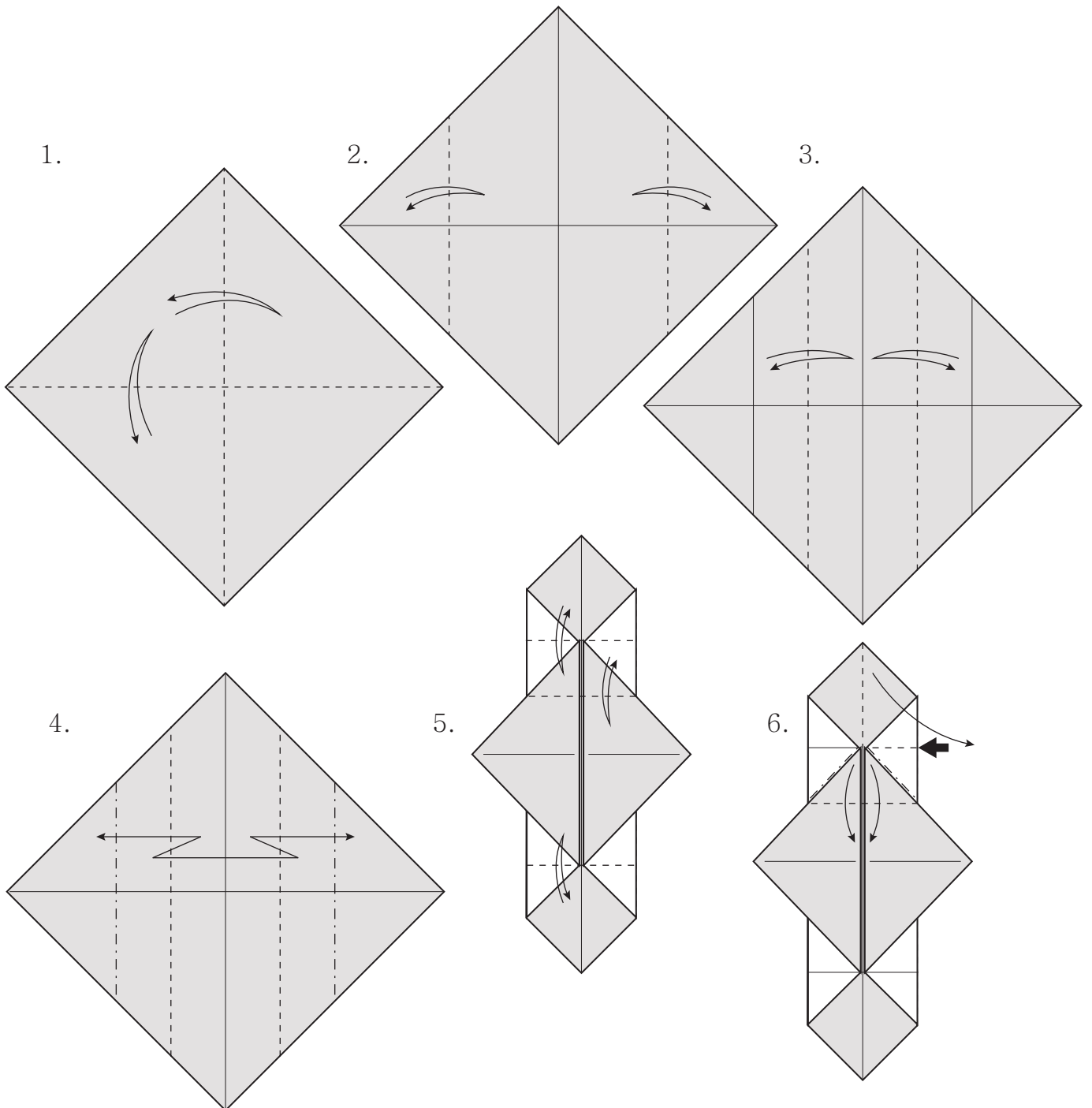
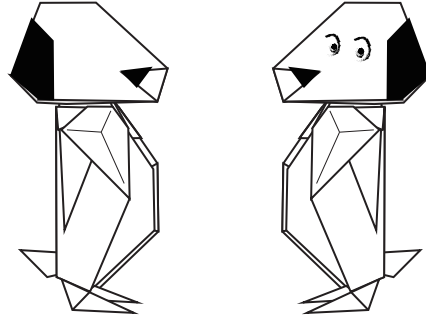

양편 계단접기 하세요.

7.

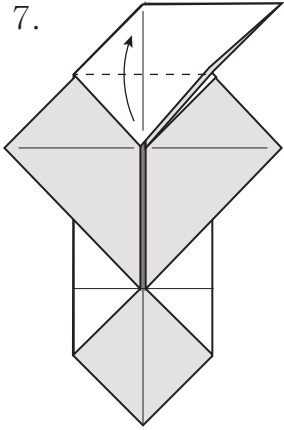

8.

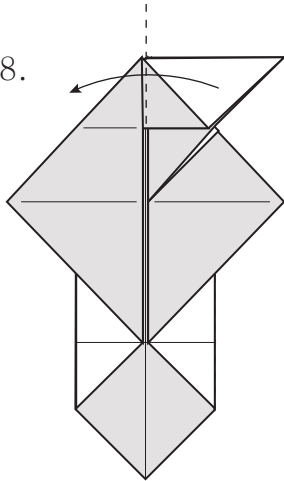

9.

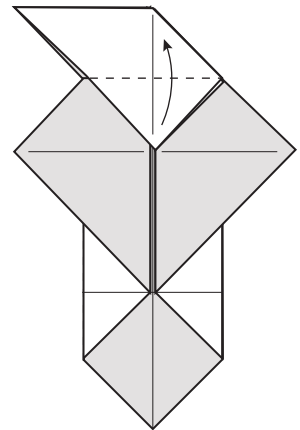

10.

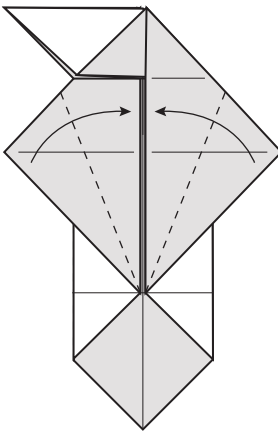

11.

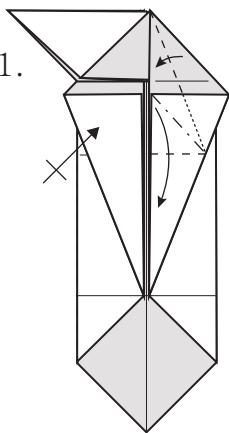

12.

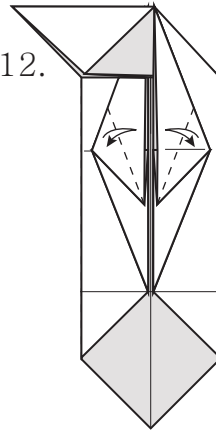

13.

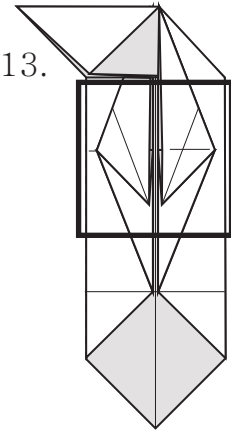

14.

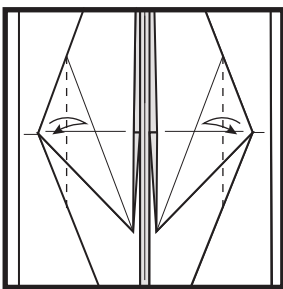

15.

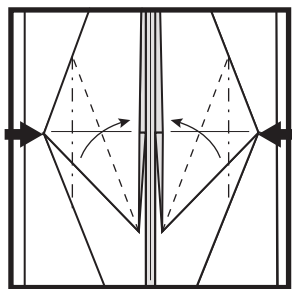

16.

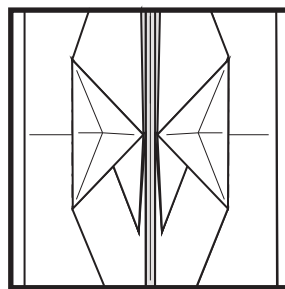

17.

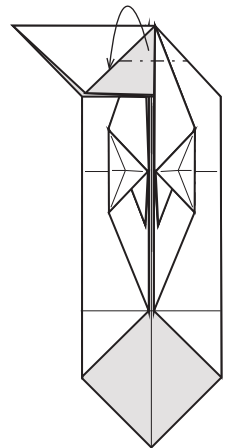

18.

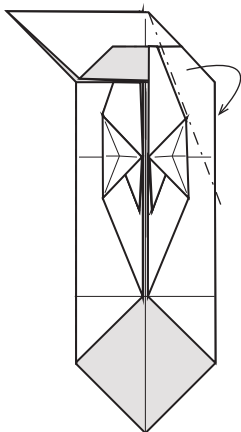

19.

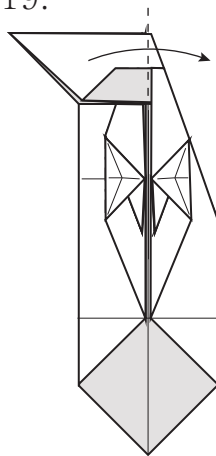

20.

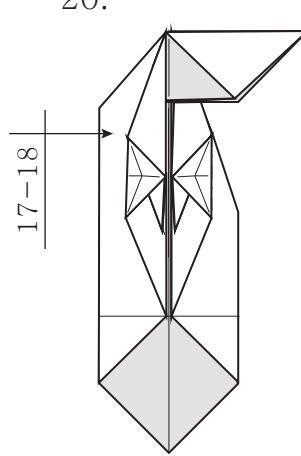

21.

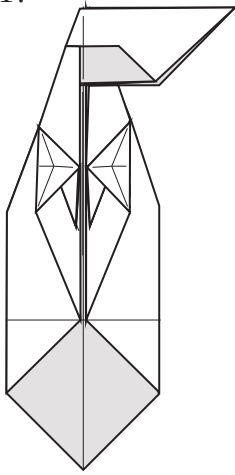

22.

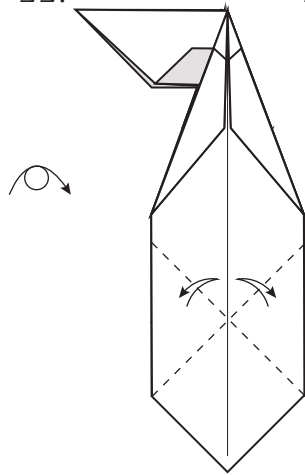

23.

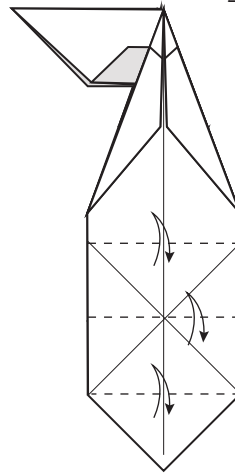

24.

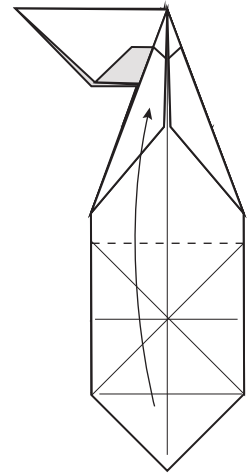

25.

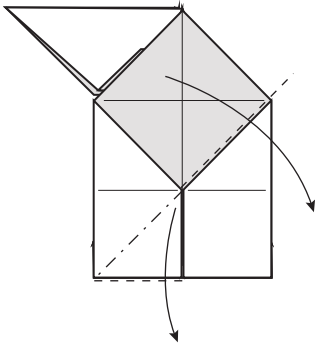

26.

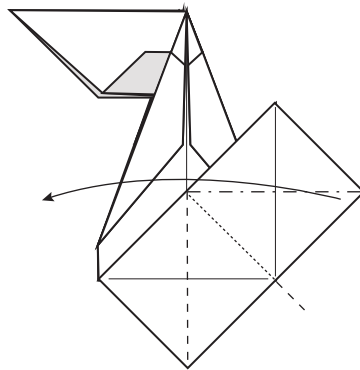

27.

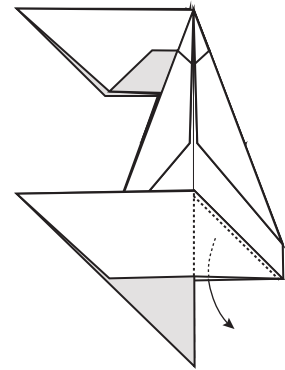

28.

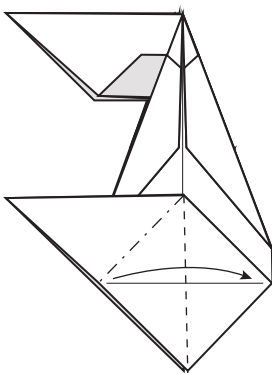

29.

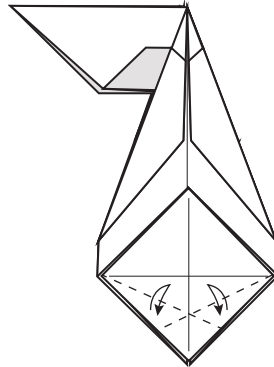

30.

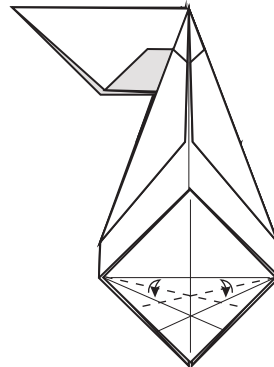

31.

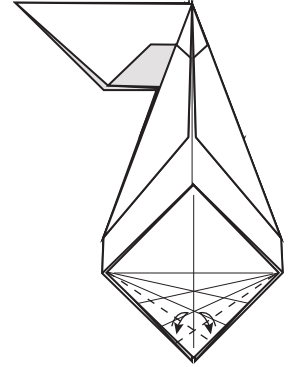

32.

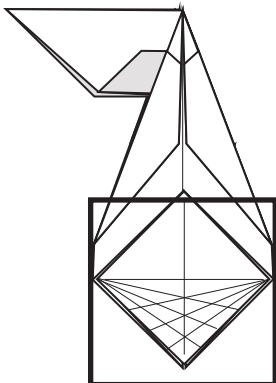

33.

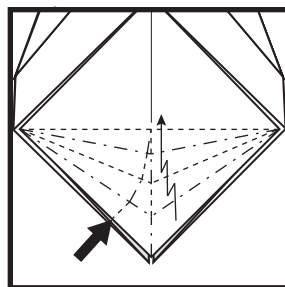

34.

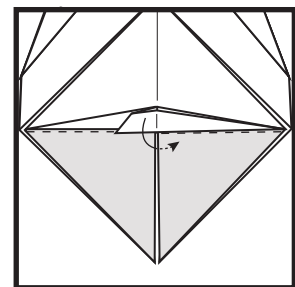

35.

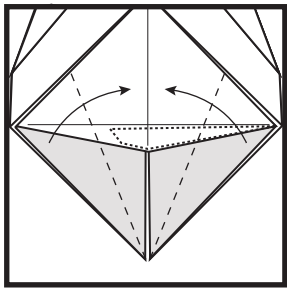

36.

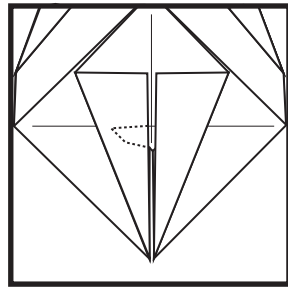

37.

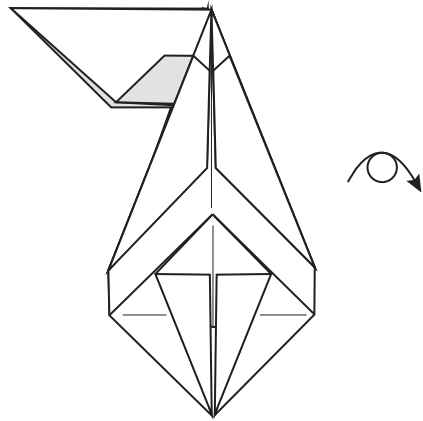

38.

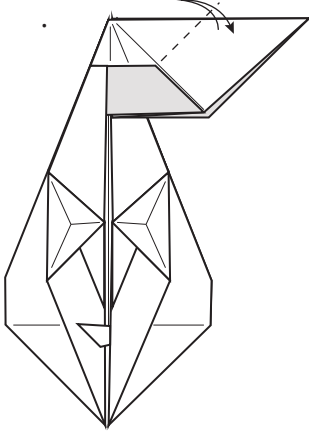

39.

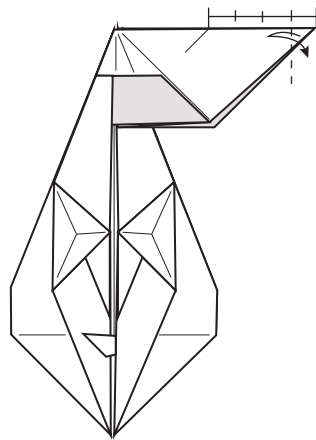

40.

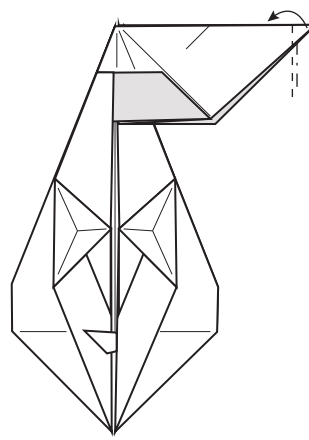

41.

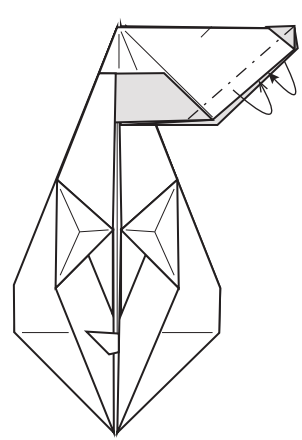

42.

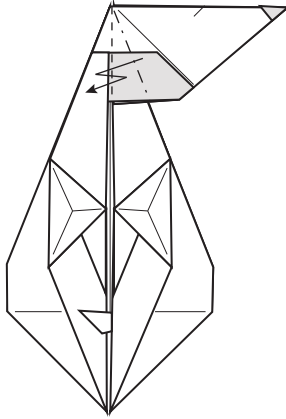

43.

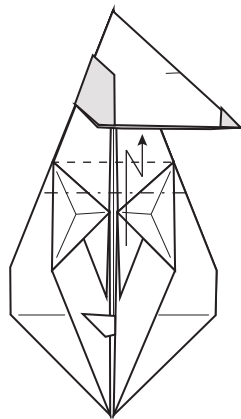

44.

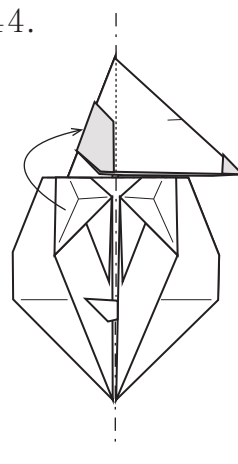

45.

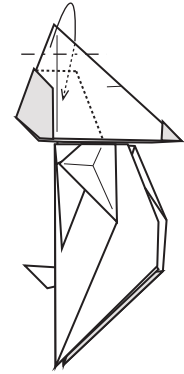

뒤쪽 주머니에 넣어주세요.

46.

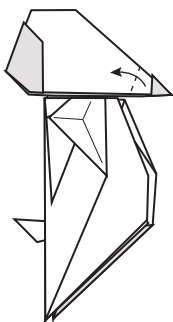

47.

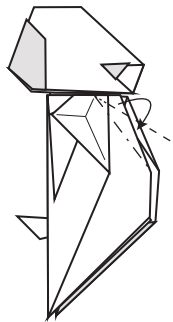

inside reverse fold

48.

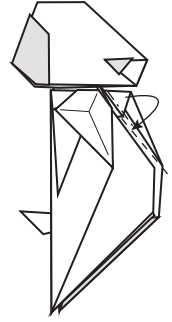

inside reverse fold

49.

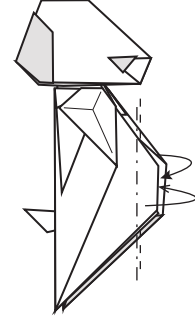

50.

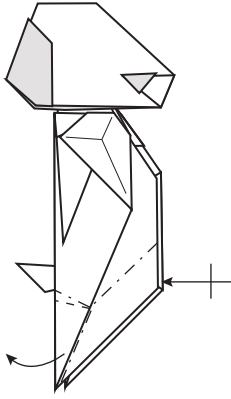

51.

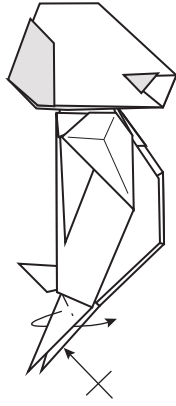

52.

