

向日葵

英文名

设计/Designer
Guitar Chiang 10/2024

制图/Diagrams
黄忆什 10/2024

纸张大小/Paper Size
15 x 15 cm

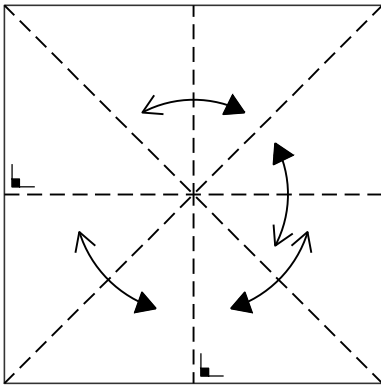
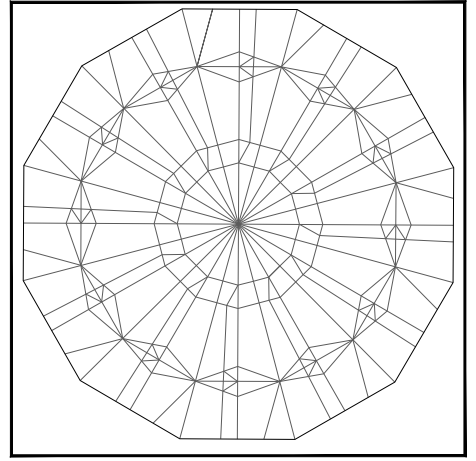
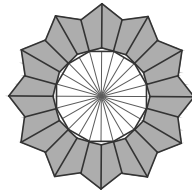

01.

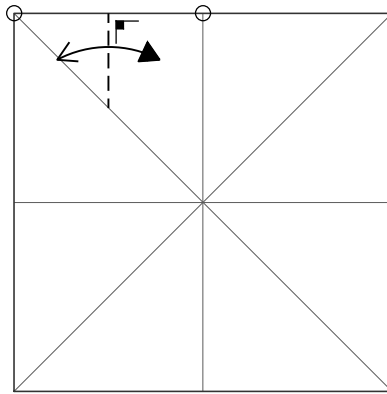

02.

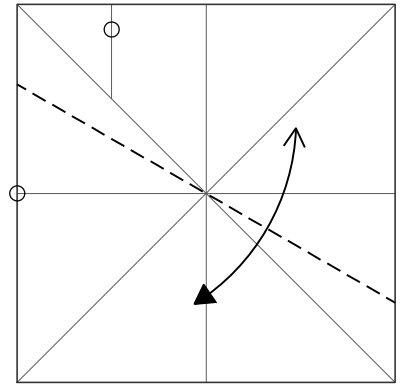

03.

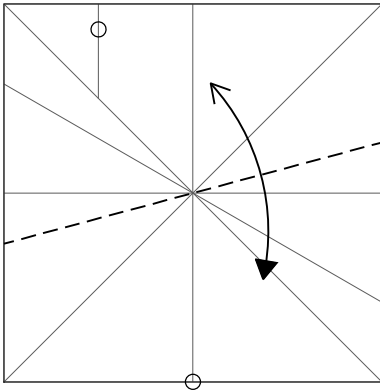

04.

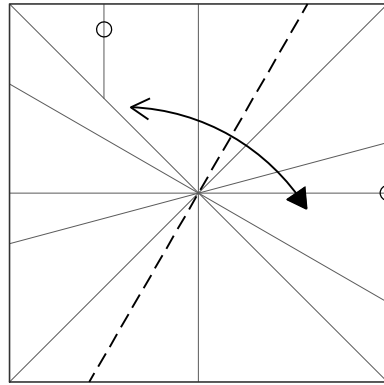

05.

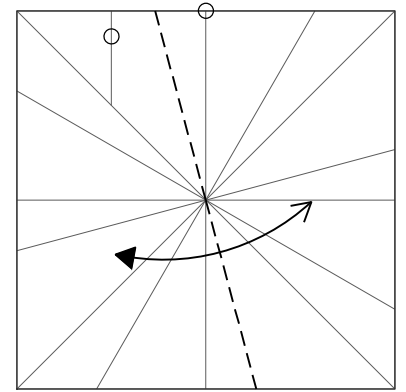

06.

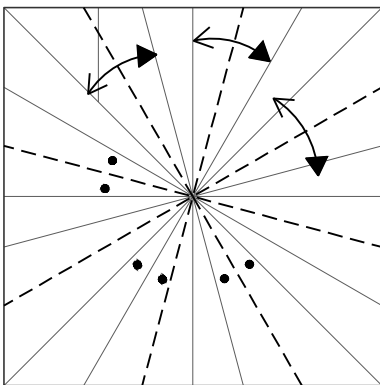

07.

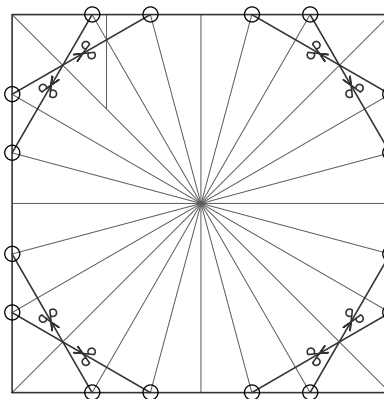

08. 沿着点裁剪

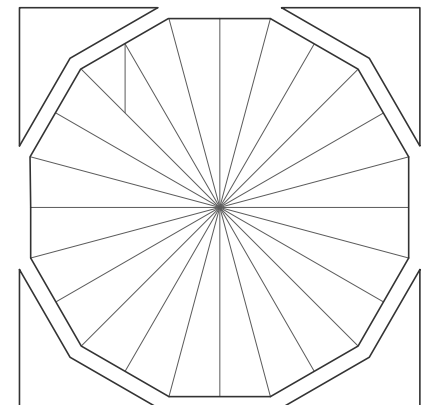

09. 正十二边形

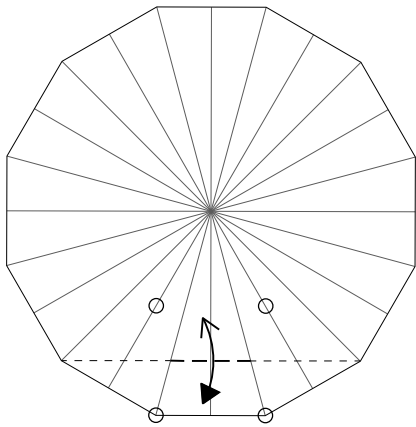

10. 沿着点折出折痕

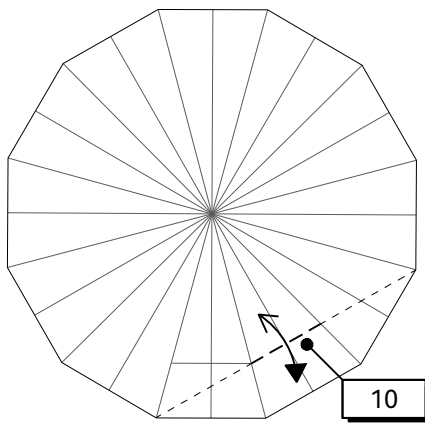

11. 同10折出折痕

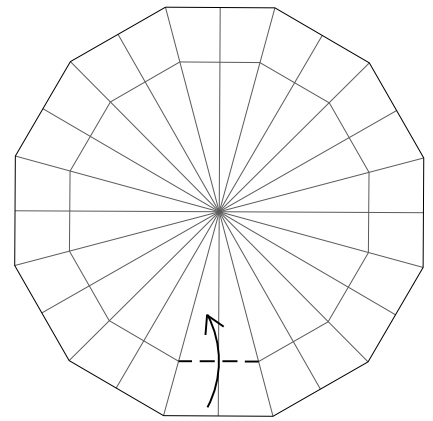

12. 沿着折痕谷折，只折谷线部分

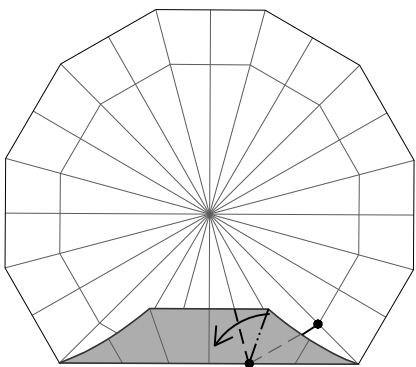

13. 沿着峰线谷线折叠，注意隐藏线只折两点之间的谷线

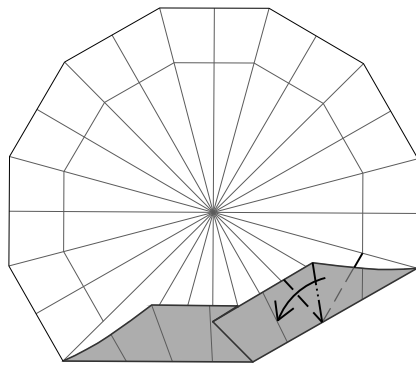

14. 和上一步相同

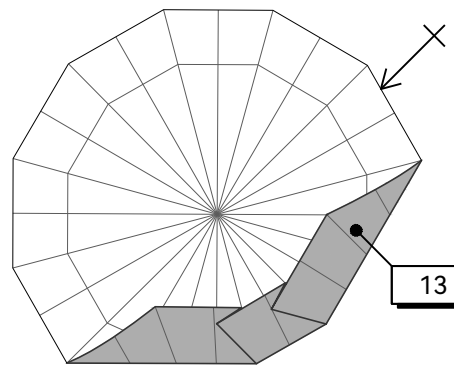

15. 重复10次第13步

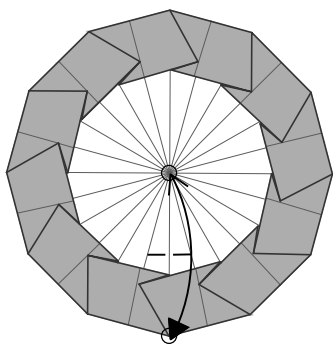

16. 沿着点折出折痕

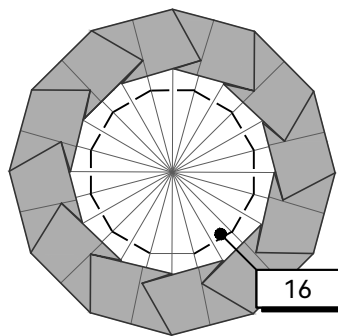

17. 同16，折出11条折痕

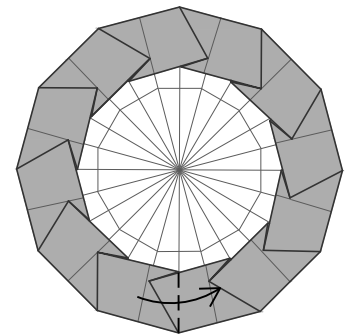

18. 沿着谷线将纸层向右折

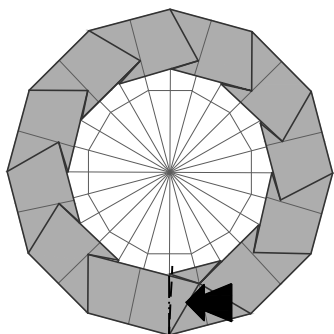

19. 沿着折痕沉折进去

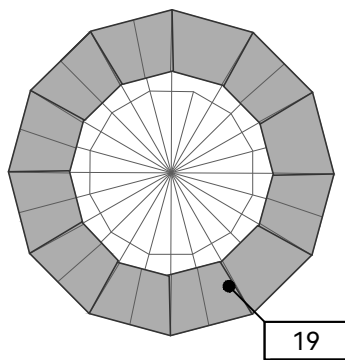

20. 其余11个角重复19

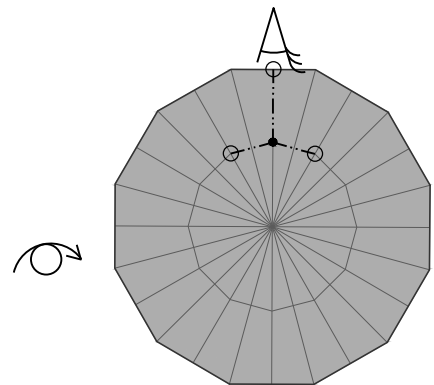

21. 折出峰线，只折到峰线部分即可注意这一步开始纸会不平

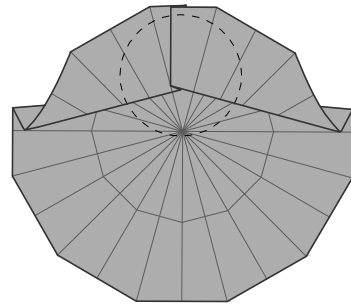
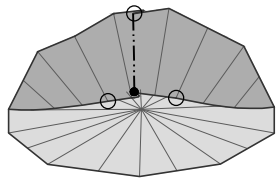
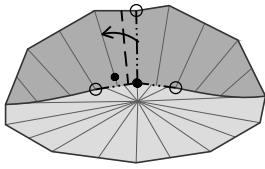

22. 立体化后，将对线，折出谷线
注意三个画圈在上一步对应的位置

23. 此时画圆部分纸张已压平
翻面

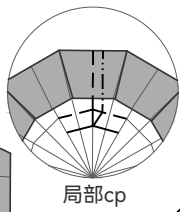
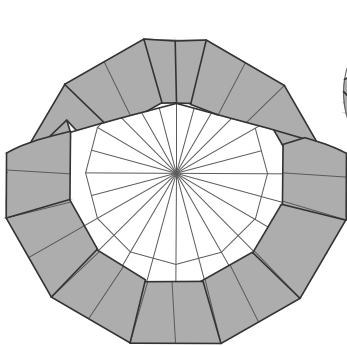

局部cp

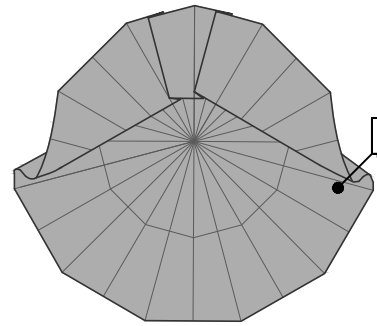
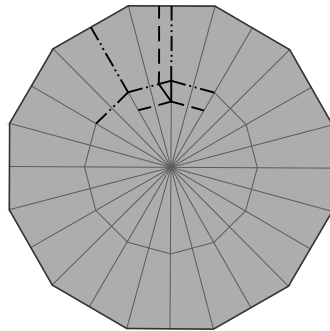

21-23

24. 模型正面，将模型恢复至20步
参考局部cp后翻面

25. 按折痕恢复至23，左侧峰线重复21-22

26. 其余部分重复21-23步

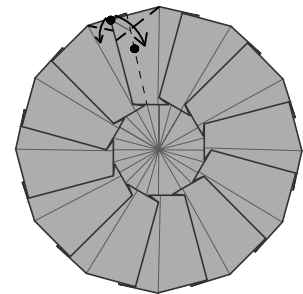
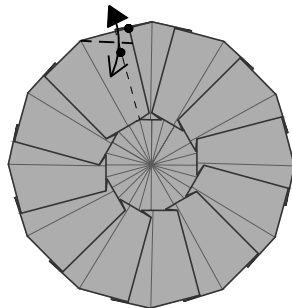
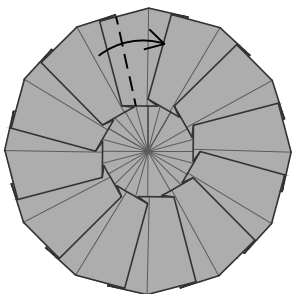

27. 沿谷线将纸层向右折

28. 点对线预折

29. 恢复到16，点对点谷折，沿着17
折痕谷折，注意隐藏线

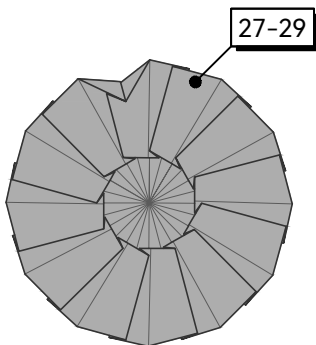

27-29

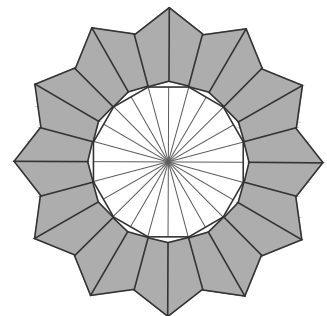
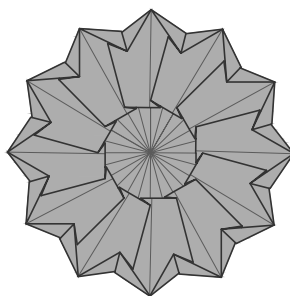

30. 其余11个部分，同28-30

31. 适当调整，使模型更加立体

32. 完成!