

# Seigaiha without cuts

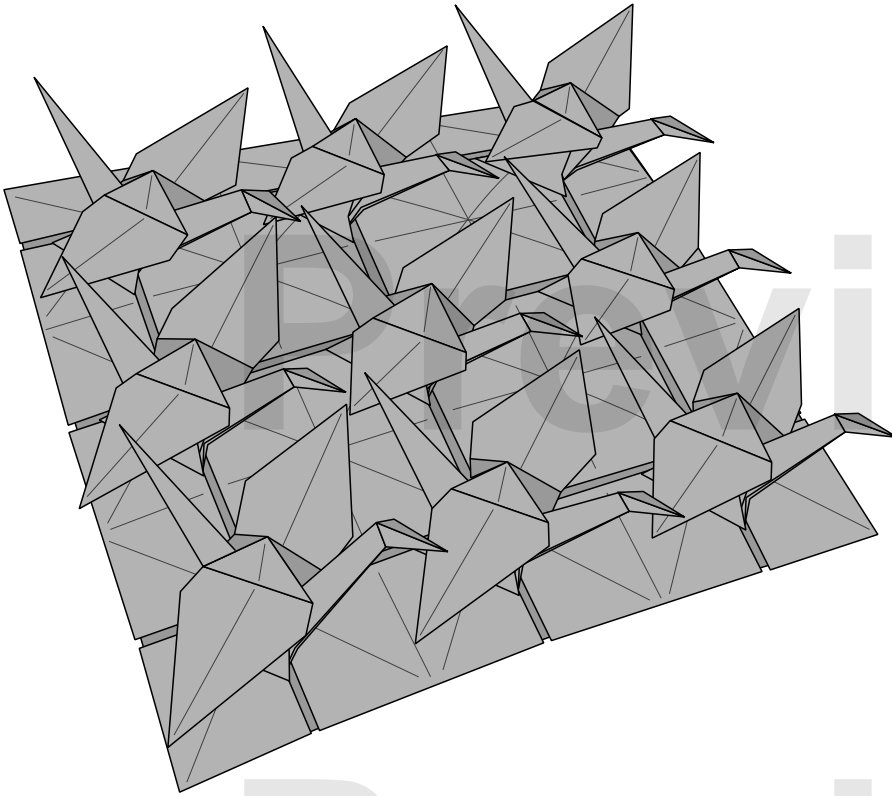

Designed by Mu-Tsun Tsai (2015.8)  
Diagrammed 2022.

Recommended sheet size: 50cm+  
The finished model is 3/16 of the sheet size.

Seigaiha (lit. wave of the blue ocean) is one of the designs found in Hiden Senbazuru Orikata. This model is the uncut version of it.

This model will require LOTS of sink/unsink operations, so it is very important to use papers that are easy to reverse creases. And of course, thinner sheets work better.

You might have seen a similar concept of "Crane on a Plane" from Robert J. Lang's *Origami Design Secrets* 2nd ed., or the "Zuru Tessellation" by S Taro, yet this model was designed independently and resulted in a quite different transitional structure and folding method.

In theory, the structure and the folding sequence of this model can be repeated arbitrarily many times to achieve even a thousand orizuru from a single square.

If you would like to try folding other numbers of orizuru, all you need to know is that each tile is a  $10 \times 10$  grid. Here I add one additional unit around the model to get the nice  $32 \times 32$  grid for nine orizurus.

1.

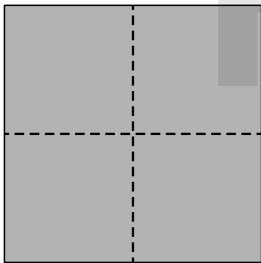

Crease.

2.

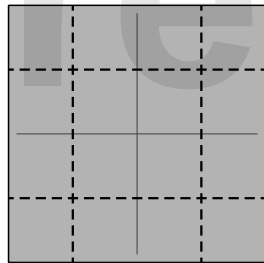

Crease into 4th.

3.

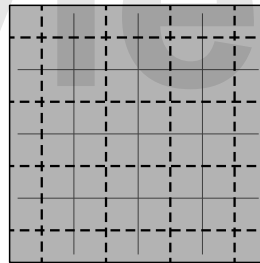

Crease into 8th.

4.

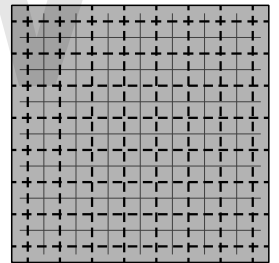

Crease into 16th.

5.

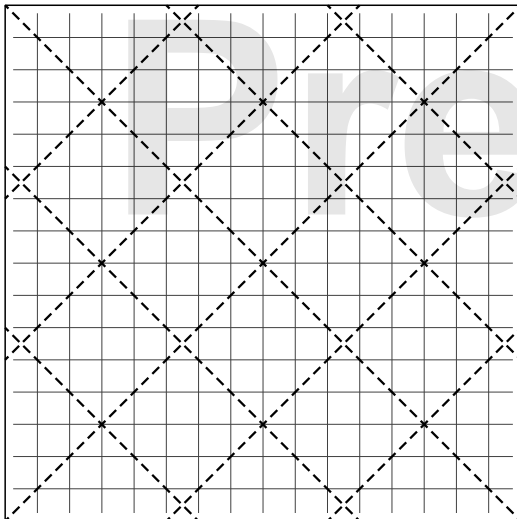

Crease along these diagonal lines.

6.

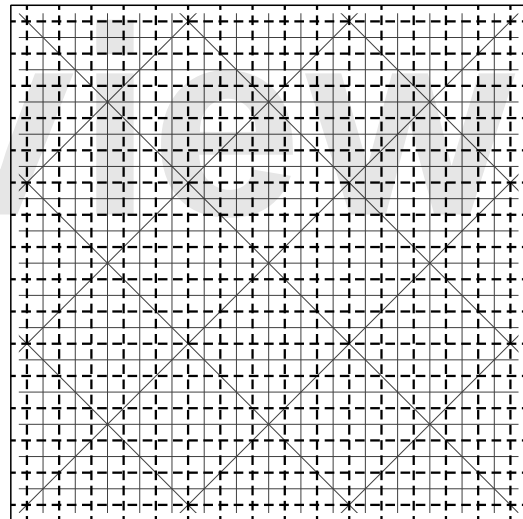

Crease into 32nd.

7.

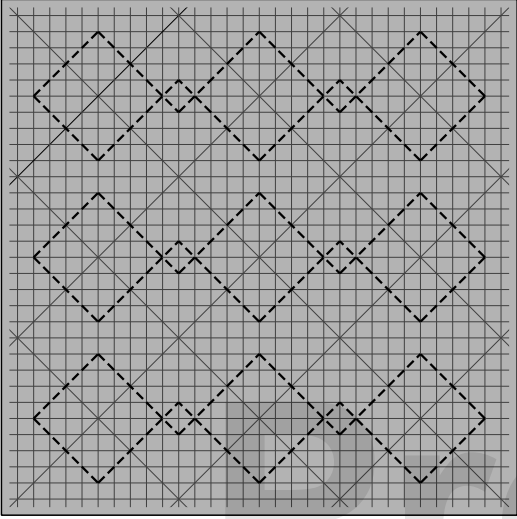

Crease along these diagonal lines.

8.

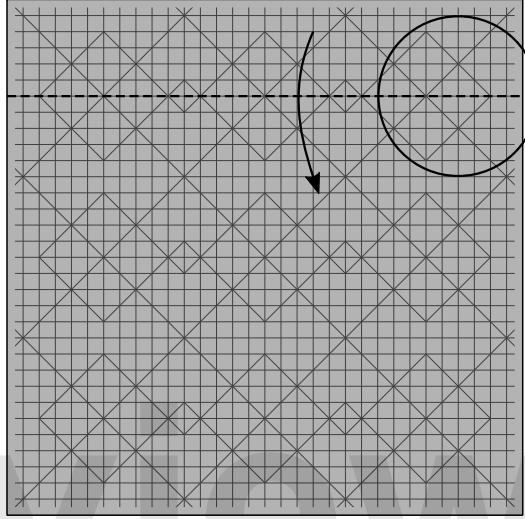

Valley-fold. Next, we'll be focusing on the circled part.

9.

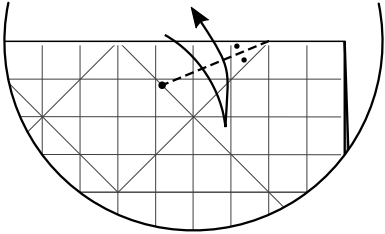

Crease angle bisectors.

10.

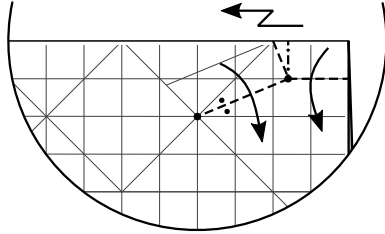

Rabbit-ear-fold. Make these creases extra sharp. The left side of the model won't be flat.

11.

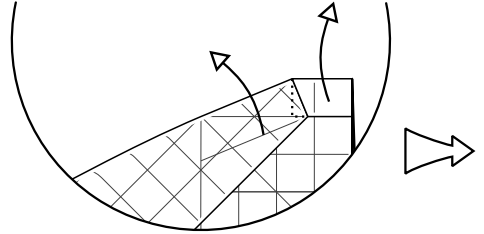

Like this. Then unfold to step 9.

12.

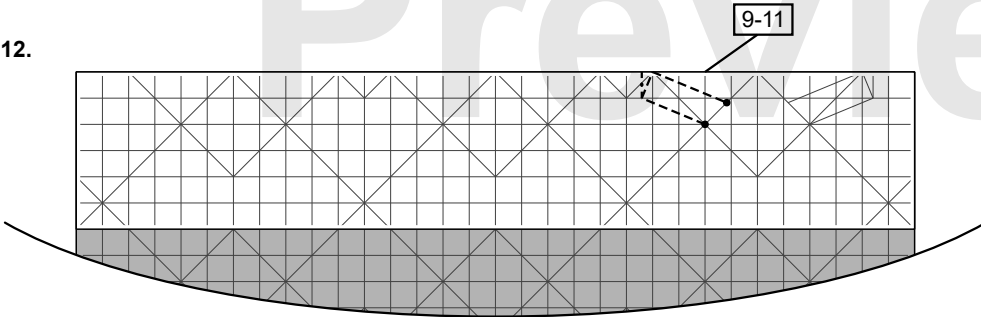

Repeat steps 9-11 in the mirror image

13.

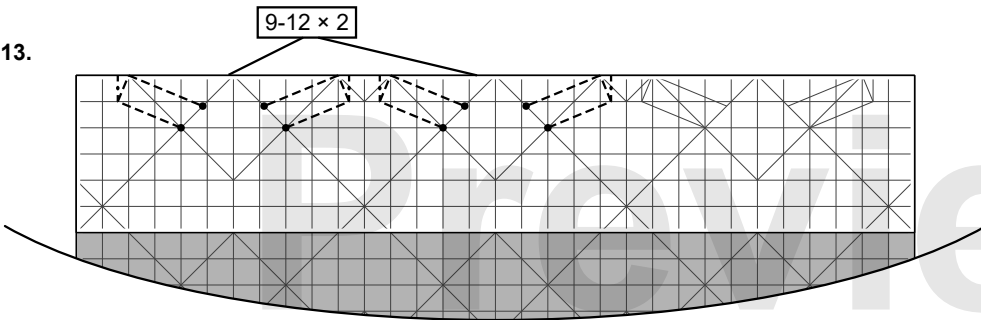

Repeat steps 9-12 two more times.

14.

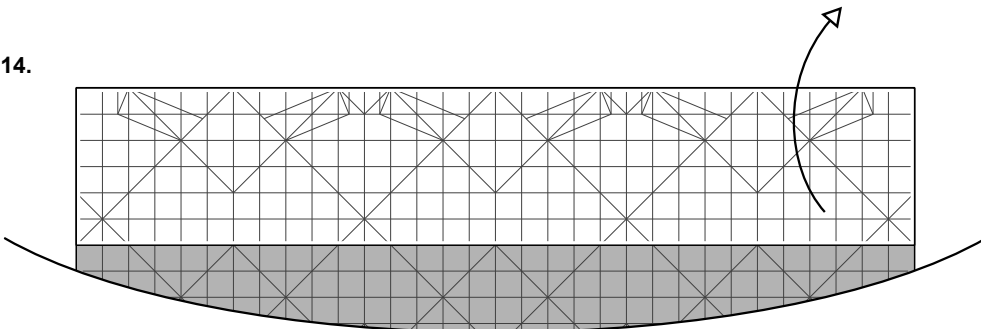

Undo step 8.

15.

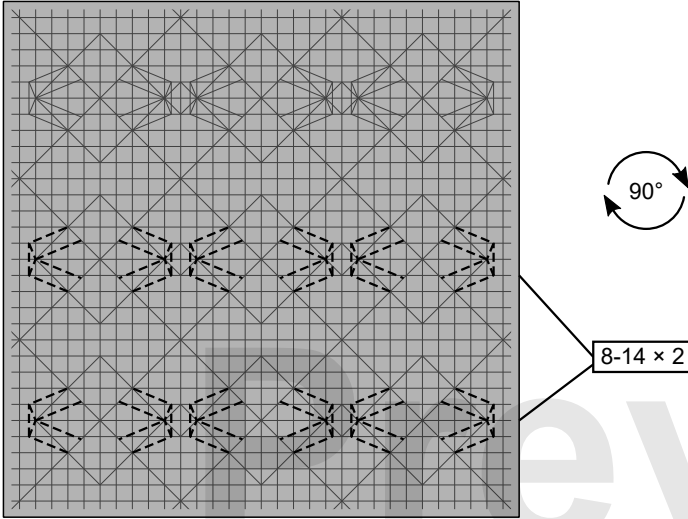

Repeat steps 8-14 two more times.

16.

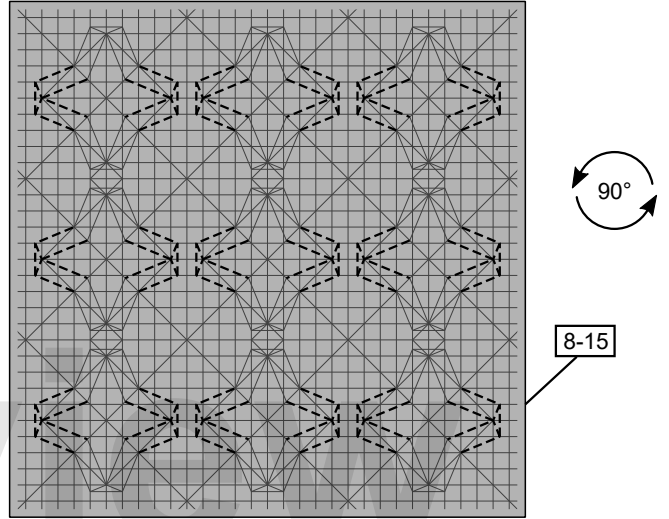

Repeat steps 8-15. Precreasing finished.

17.

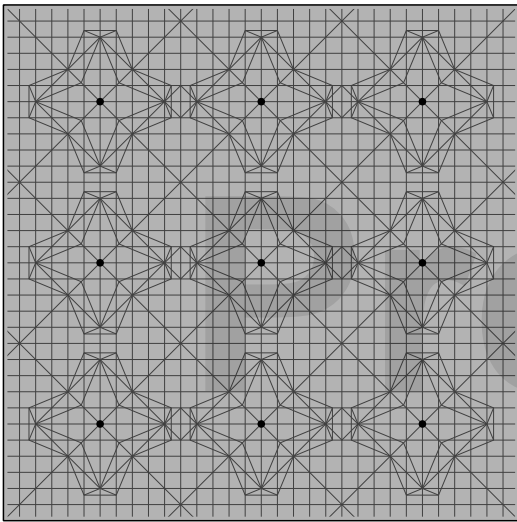

(Optional) Enhance these points from the inside with scotch tapes to prevent tearing later on.

18.

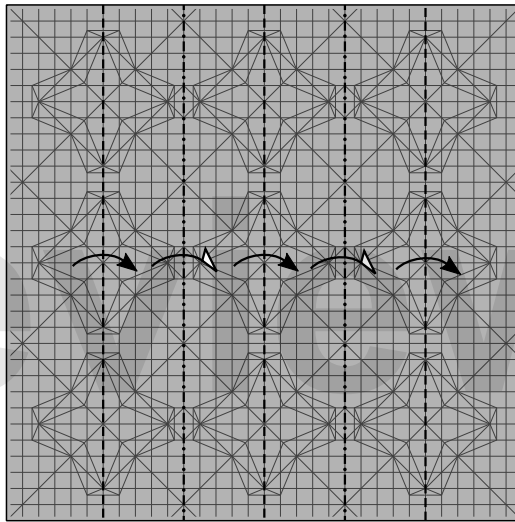

Initial collapse. Pay attention to the sheet orientation here.

19.

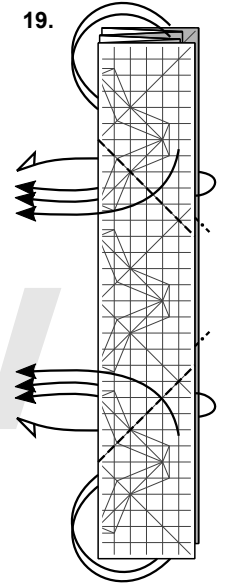

Multiple-reverse-fold.

20.

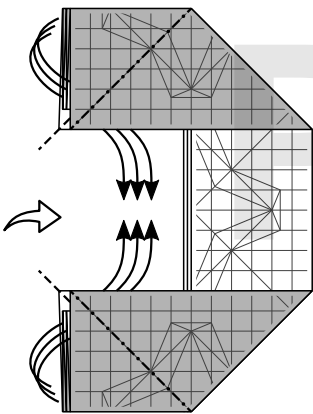

Multiple-reverse-fold.

21.

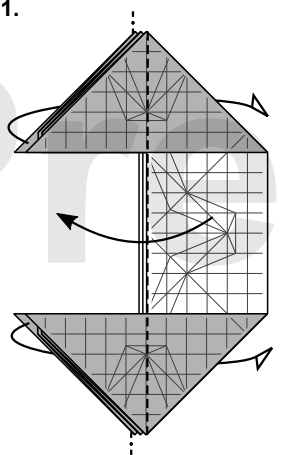

Fold one layer to the left on the front, and fold one layer to the right behind (both top and bottom).

22.

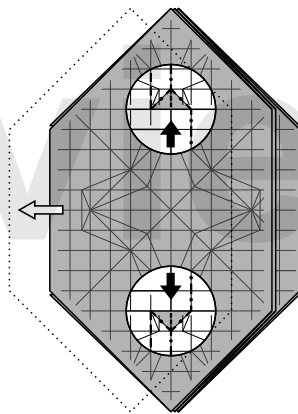

Pleat the near layer to the left by adding gussets inside (using precreases made in step 7) as shown in the x-ray views.

23.

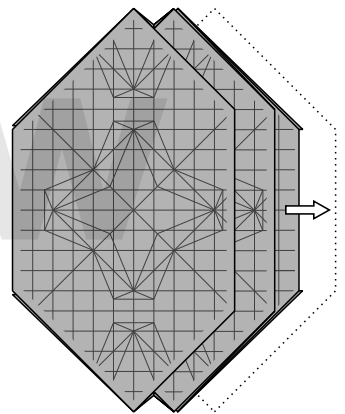

Pleat the far layer to the right in the same way.

24.

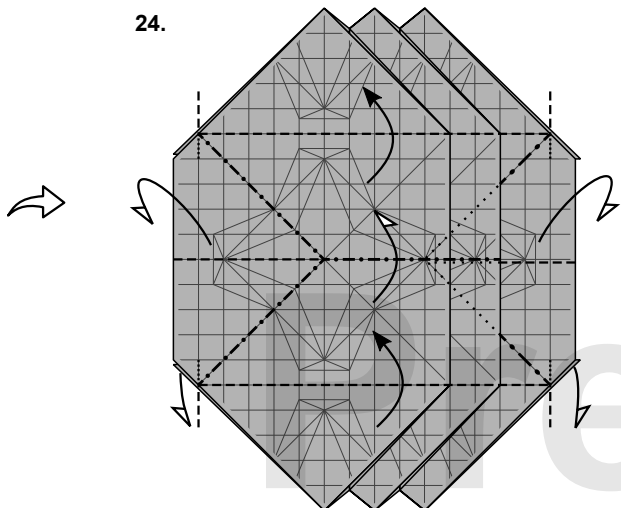

Collapse as shown. Reverse-fold only one layer on the right side. A tiny layer will stretch out at each of the four corners as you made the reverse folds. Revolve one unit from the far layers as you made the horizontal valley folds near the top and bottom. The result is flat.

25.

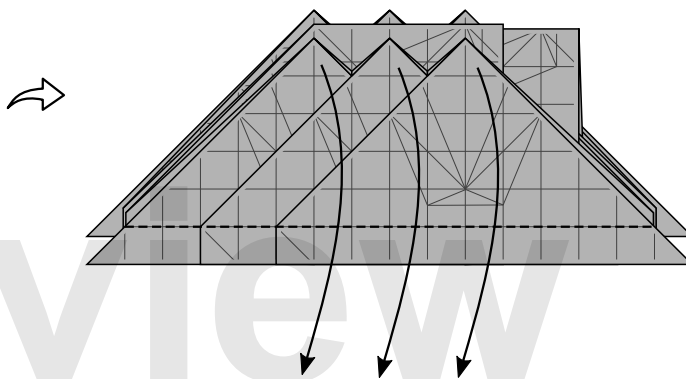

Fold three tips down together as far as possible.

26.

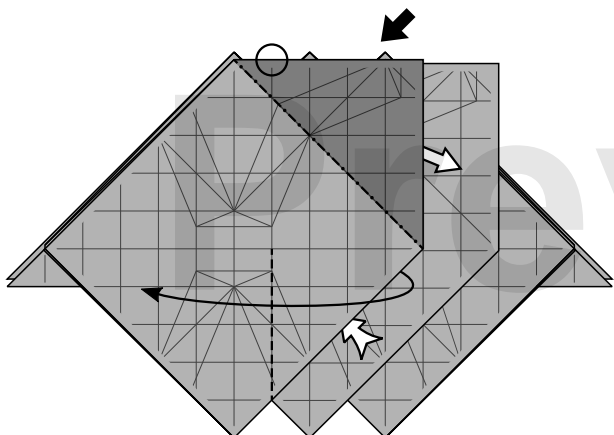

Sink the shaded part by opening the pocket and carefully pull out the circled hidden corner inside. The model will not lie flat...

27.

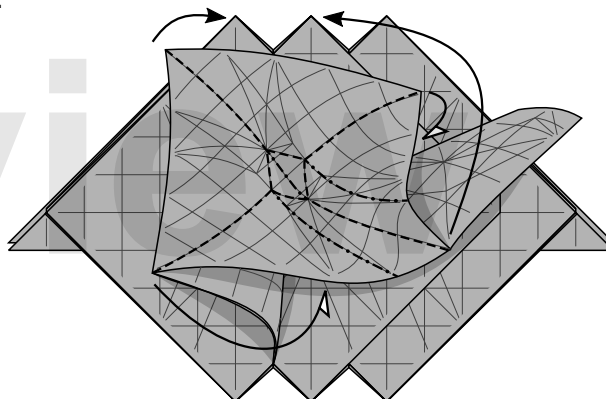

...Then flatten the model as shown. The pattern is very similar to the one we made in step 22.

28.

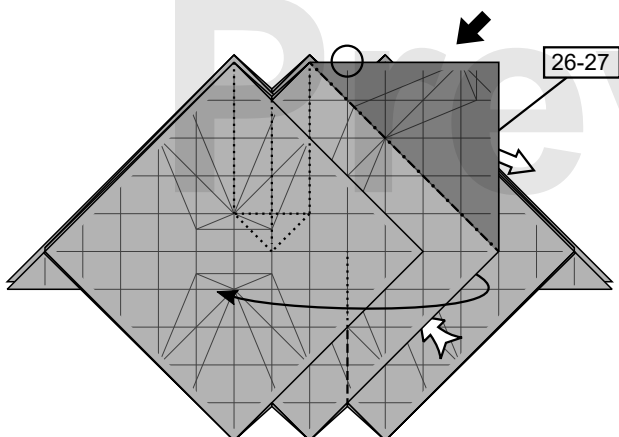

The inner structure is shown by the dot lines. Now repeat steps 26-27 on the next hidden corner.

29.

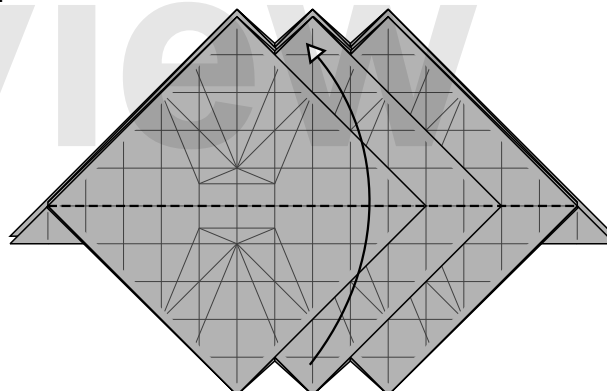

Unfold three tips.



121.

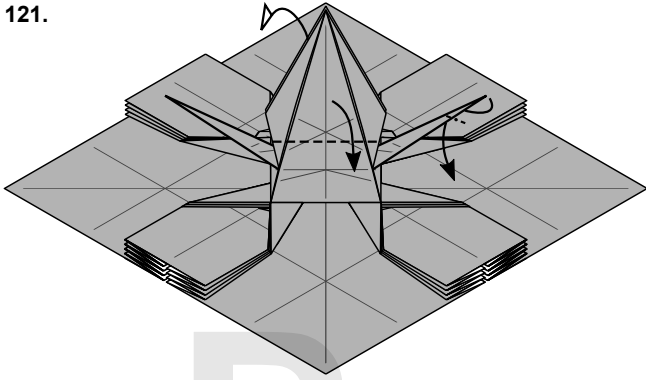

Open the wings and inside-reverse-fold the head. Repeat steps 118-121 on the other eight groups.

122.

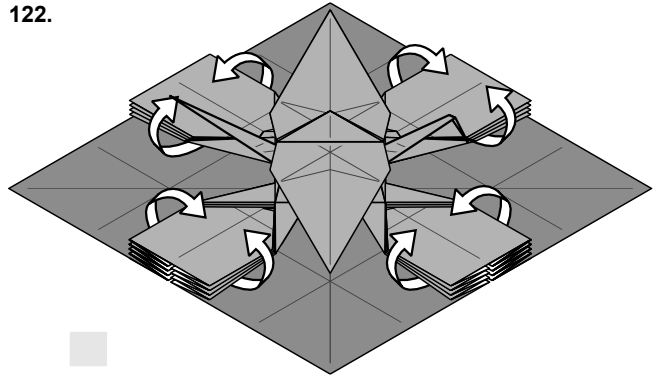

Closed-wrap the bottom-most layers to the top. It is easier to do this from the underside. Repeat this for the whole model. There are a total of 16 of them.

123.

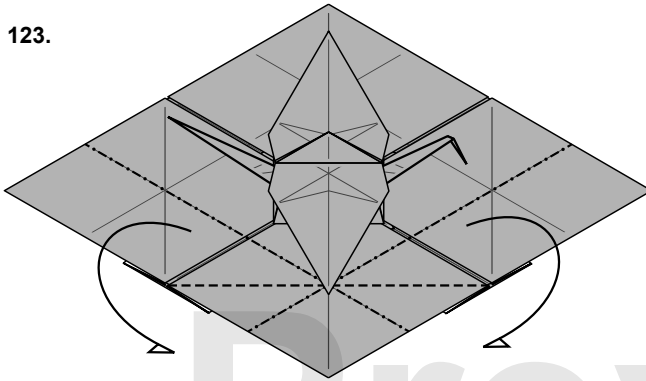

There is one extra unit around the entire model. Mountain-fold it underneath to lock the pleats (shown here is the pattern around the corner of the model). You could perform additional lock folds around the corners if you like.

124.

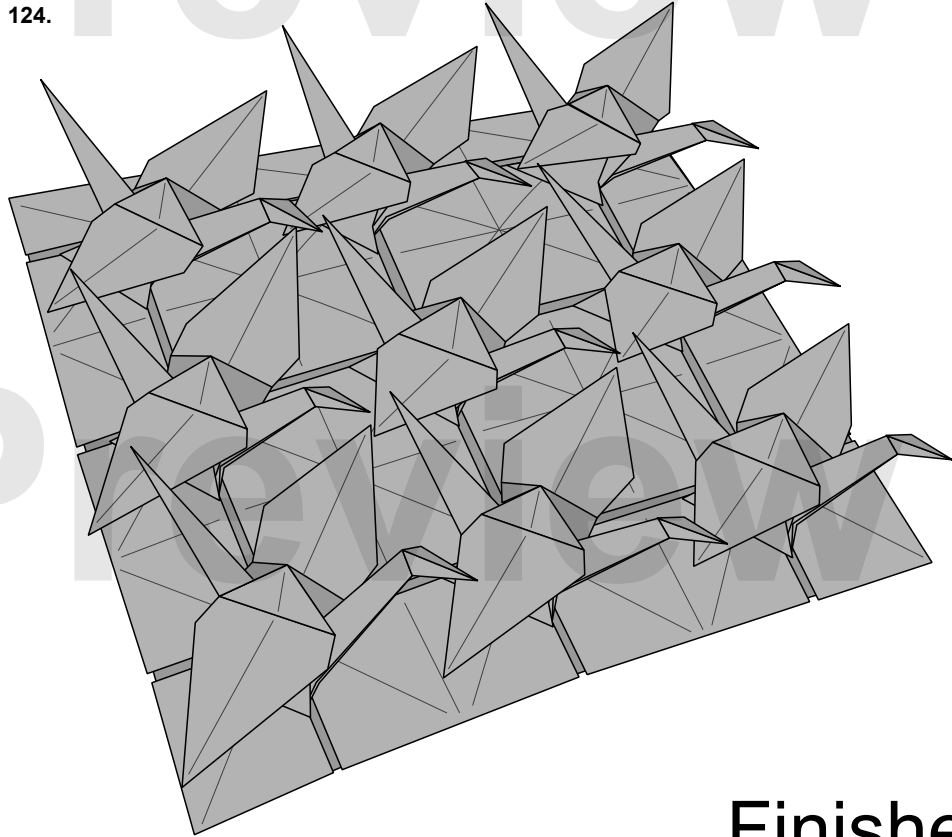

Finished